

ADF4355-2 – Bypass VCO Calibration

BYPASS VCO CALIBRATION FOR FASTER LOCK TIMES

For any given output frequency, the ADF4355-2 uses a certain VCO core, band, and bias code. These three settings are selected automatically during the VCO autocalibration. The settings can be read from the ADF4355-2 and stored in a lookup table. This lookup table can then be used to bypass the autocalibration routine and hence dramatically decrease the total lock time when changing frequency. For example, lock times of less than 30 μ s are possible with a 60 kHz loop bandwidth. An example of a suitable filter is shown in Figure A.

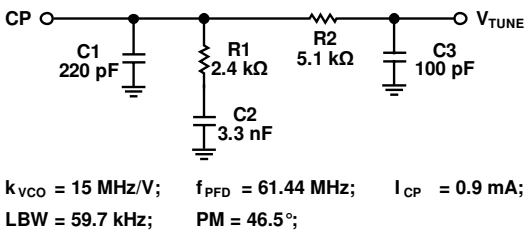

Figure A. Example loop filter with a 60 kHz bandwidth

Each ADF4355-2 chip is unique so a new lookup table must be generated for every chip.

VCO Readback Procedure

1. Load all registers to lock to desired frequency.
 - a. Ensure VCO Read is set to VCO Core and Band (R10, DB[28:26] = 1).
 - b. Ensure VCO Readback is set to VCO Calibration Complete (R7, DB[15:12] = 6).
 - c. Ensure Muxout is set to VCO Readback (R4, DB[29:27] = 7).
 - d. Ensure Autocal is enabled (R0, DB21 = 1).
2. Wait until Muxout outputs a logic high (VCO calibration complete).
3. Load R7 with VCO Readback set to VCO Readback (R7, DB[15:12] = 7).
4. Pulse SPI CLK while LE is kept high. Data is output on Muxout. Extract data as shown in Figure B.
5. Load R10 with VCO Read set to VCO Bias (R10, DB[28:26] = 3).
6. Repeat step 3 for bias data.
7. Repeat steps 1 – 5 to build a look up table for all desired frequencies. For step 1, it is only required to

write R10, R7, [R2], [R1], and R0, after the first iteration. (R2 and R1 are optional if they have not changed.)

DATA CLOCKED OUT ON POSITIVE EDGE OF CLK AND READ ON NEGATIVE EDGE OF CLK. READBACK STARTS ON FIRST CLK AFTER LE GOES HIGH. LE MUST STAY HIGH DURING READ.

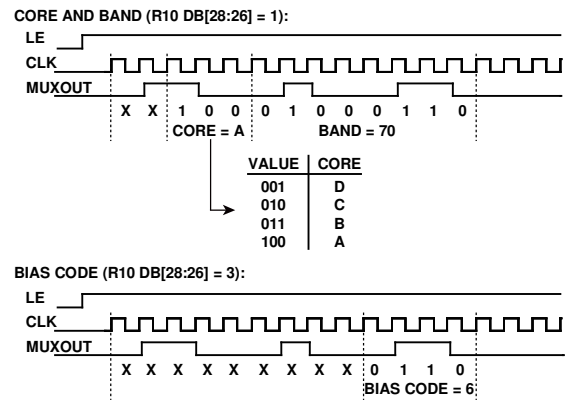

- NOTES:
- X = DON'T CARE.
 - MUXOUT MUST BE SET TO VCO READBACK (R4, DB[29:27] = 7).
 - VCO READBACK MUST BE SET TO VCO READBACK (R7, DB[14:12] = 7).

Figure B. VCO Readback

Bypass Autocal to Manually Selected VCO and Lock

If the required VCO core, band, and bias code for a desired frequency are known (for example, in a lookup table), the VCO calibration routine can be bypassed and the VCO data set manually.

1. Load R0 with Autocal disabled (R0, DB21 = 0). This step is optional if Autocal is already disabled.
2. Load R10 with VCO Write set to VCO Core and Band (R10, DB[31:29] = 1).
3. Load R11 with VCO core, band, and bias code set as defined in Figure F. Note VCO core bits are different for read and write.
4. Load R10 with VCO Write set to VCO Bias Code (R10, DB[31:29] = 3).
5. Reload R11 with the same value as in Step 4.
6. Lock to desired frequency by programming R2, R1, and R0 in that order.

Expanded ADF4355-2 register maps

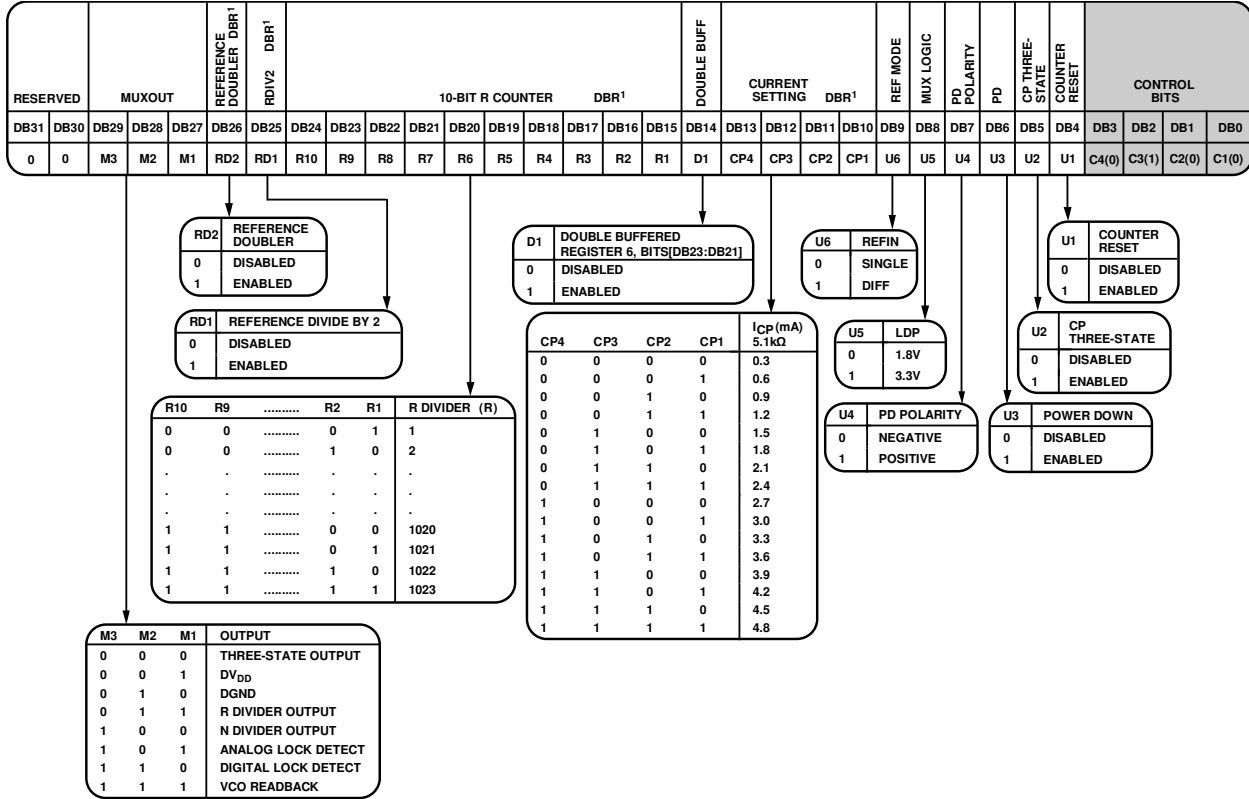

¹DBR = DOUBLE BUFFERED REGISTER—BUFFERED BY THE WRITE TO REGISTER 0.

Figure C. Register 4

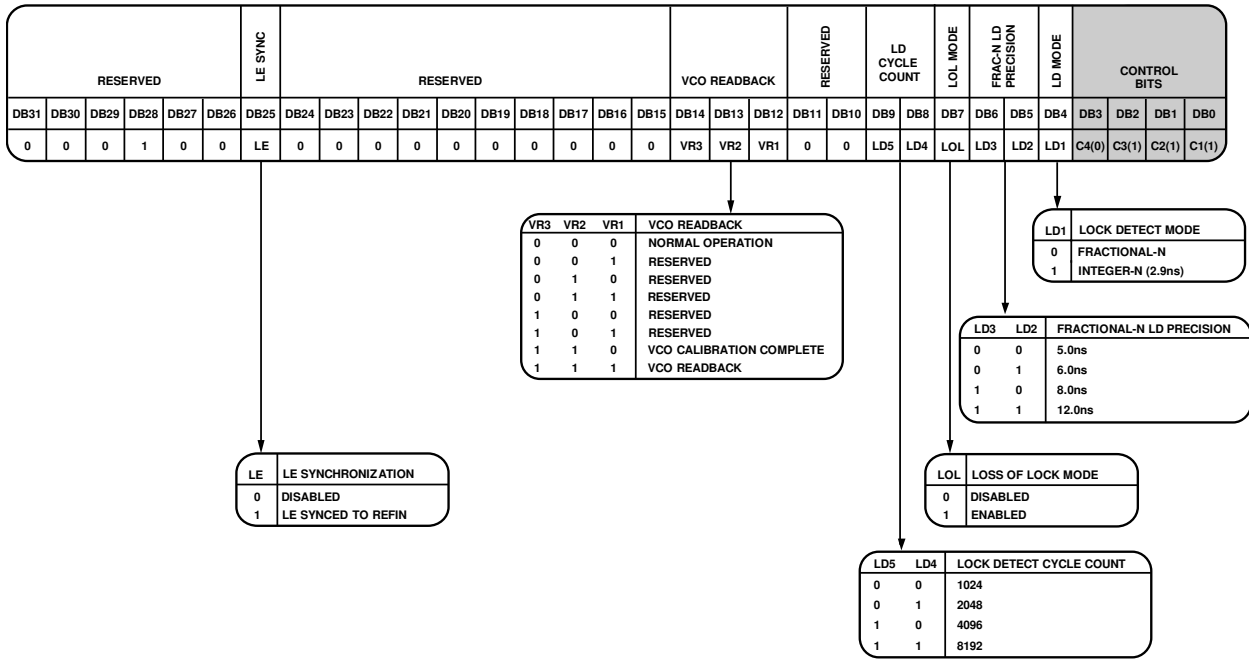

Figure D. Register 7

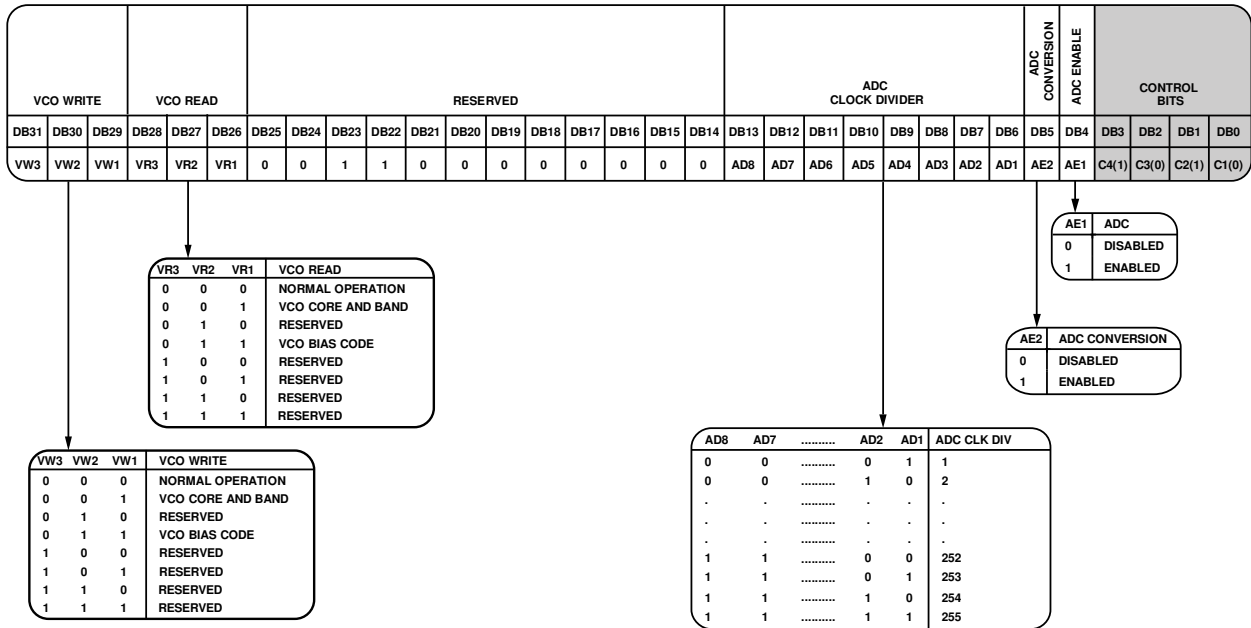

Figure E. Register 10

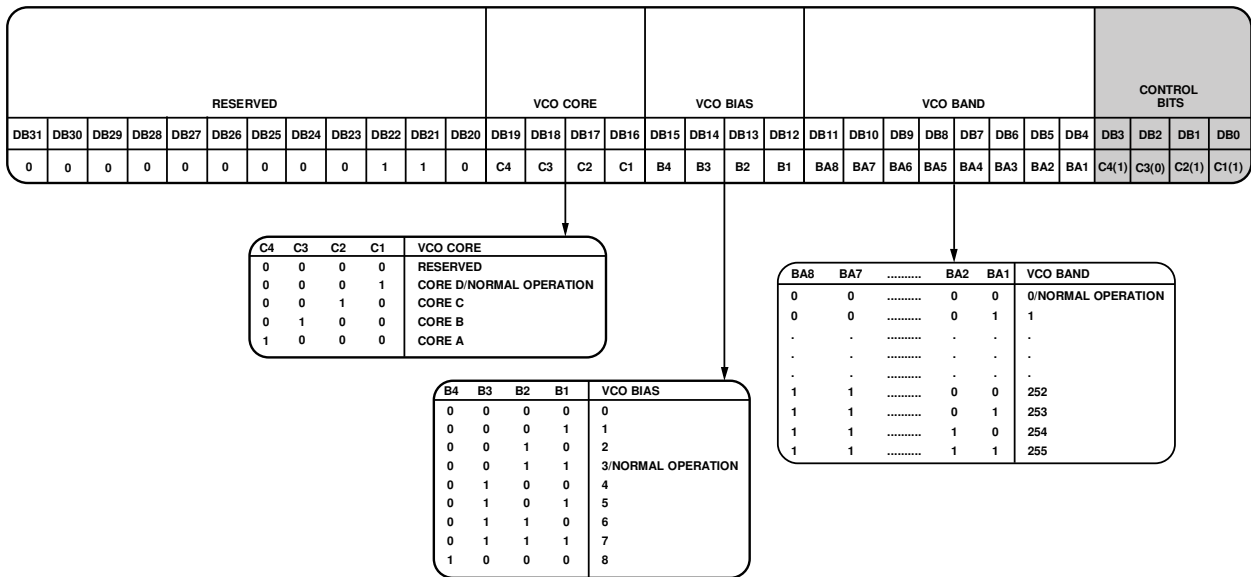
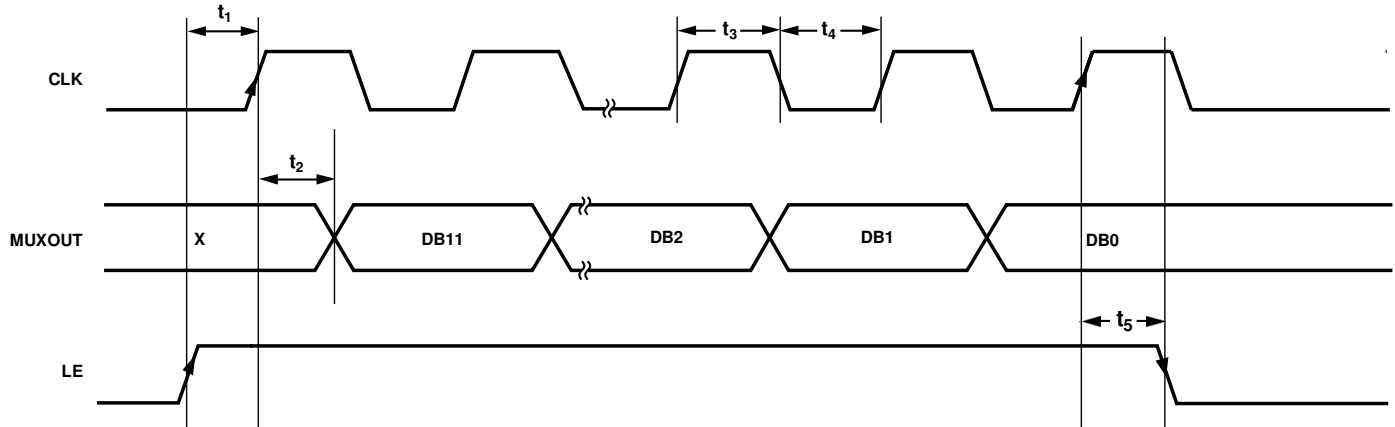

Figure F. Register 11

Table X. Read Timing

Parameter	Limit at T _{MIN} to T _{MAX}	Unit	Description
t ₁	15	ns min	LE high to CLK high
t ₂	15	ns min	CLK high to DATA ready
t ₃	25	ns min	CLK high duration
t ₄	25	ns min	CLK low duration
t ₅	10	ns min	CLK high to LE low (next write)

Read Timing Diagram



NOTES
 1. LE SHOULD BE KEPT HIGH DURING READBACK.
 2. X = DON'T CARE.

Figure G. Read Timing Diagram