

53210A/53220A/53230A Option Installation

Introduction	2
Tools Required	2
Do This First	2
Removing the Cover and Rear Bezel	3
Moving the Internal Battery (Option 300)	5
Moving the Optional Channel Assembly (Option 106)	6
Ultra-High Stability Timebase (Option 010)	7
GPIB Interface (Option 400)	7
Internal Battery DC Power (Option 300)	9
53210A/53220A/53230A Rear Panel Parallel Inputs (Option 201)	16
53210A Channel 2 Front Panel Input (Option 106 and Option 202)	17
53210A Channel 2 Rear Panel Input (Option 106 and Option 203)	27
53220A/53230A Channel 3 Front Panel Input (Options 106 and 202)	31
53220A/53230A Channel 3 Rear Panel Input (Options 106 and 203)	40
53230A Option 150 (Pulse Microwave Measurements)	43

This document contains installation instructions for the options available with the Agilent 53210A/53220A/53230A RF and Universal counters.

© Agilent Technologies, Inc. 2010, 2013
Printed in Malaysia E0613
Edition 2 June 2013



53200-90020



Introduction

The following information generally applies to all options.

Tools Required

The following tools are required for the installation procedures:

- Hand TORX, 8 screwdriver (T8)
- Hand TORX, 10 screwdriver (T10)
- Hand TORX, 20 screwdriver (T20)
- 7-mm spintight or 9/32" manual nut driver (GPIB connector screws)
- 14-mm deep-socket or deep spintight (TypeN and BNC connectors)
- 1/4" spintight (Option 115 standoffs)
- 5/16" open-end wrench (SMA connectors)
- Long-nose Pliers
- 3/16" or 1/4" wide medium slot screwdriver

Do This First

NOTE

Before performing any of the retrofit procedures turn the counter off and remove ac line power from the rear ac line socket.

WARNING

Hazardous Voltages exist on some internal circuits of the counter. After disconnecting the AC line power cord, wait at least 6 minutes for the High-Voltage capacitors to discharge before removing the cover.

CAUTION

ESD damage caused by customer access to the internal circuits of the counter without proper ESD protection may void the instrument warranty.

Except for Option 010 (Ultra-high stability timebase), disconnect the Option 300 internal battery, if installed, as described in the section “Moving the Internal Battery (Option 300)”.

To prevent Electrostatic Discharge (ESD) damage to the counter, place the counter on a static-safe mat that is grounded to earth ground.

Ensure that you are wearing a static-safe wristband that is grounded to the mat and to earth ground.

CAUTION

DO NOT swap the motherboard, the processor board, or the front panel board from one instrument to another. These boards contain model number and serial number information that uniquely identifies a specific unit, and boards that are mismatched to the instrument may result in problems with its performance, licensing, serviceability, importability/exportability or warranty.

Removing the Cover and Rear Bezel

The follow steps are for removing the cover and rear bezel. The cover is removed to access the board and cable assemblies, and all other internal parts.

WARNING

When the cover is removed from the instrument line voltages are exposed which are dangerous and may cause serious injury if touched. Disconnect power and wait six minutes before starting.

1. Turn off power and remove the power cord.
2. Remove the handle by rotating it to the vertical position and pulling the ends outward as shown in Figure 1.

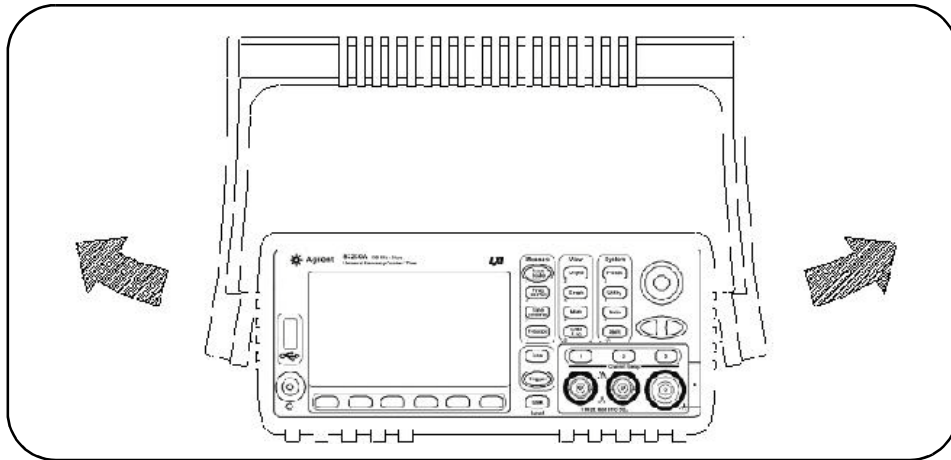

Figure 1. Removing the Handle.

3. To remove the rear bezel and cover, loosen the captive screws on the sides as shown in Figure 2 using a Torx 20 screwdriver.

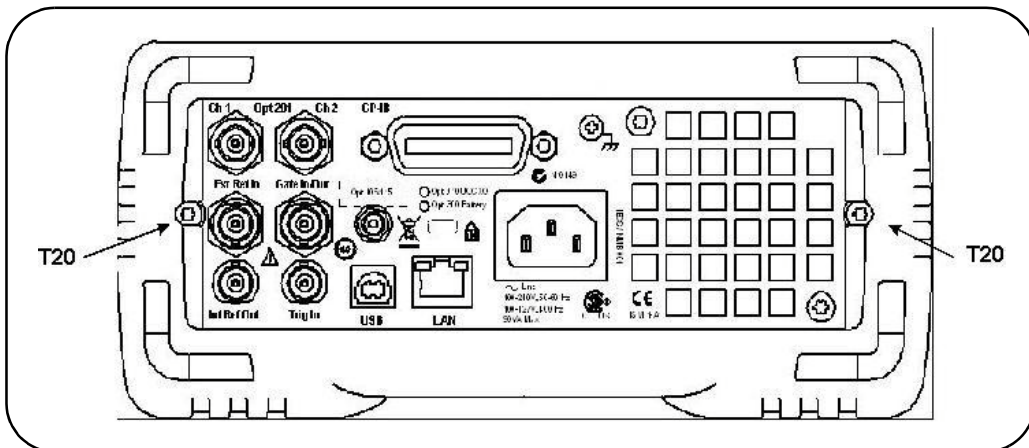

Figure 2. Rear Bezel and Cover Removal.

Moving the Internal Battery (Option 300)

When installing options it may be necessary to temporarily move the internal battery (Option 300) for easier access. To move the battery if installed:

1. Remove the two T20 TORX screws and lockwashers holding the Option 300 assembly to the left-hand side panel (as viewed from the rear of the instrument).
2. Lift up carefully on the left side of the assembly and remove the assembly from the three large tabs holding it on the right side (Figure 3). Disconnect the two cables going to the assembly.
3. Lay the assembly on its back to the right side of the chassis and place the three small tabs on the back side of the three large tabs into the three slots on the assembly deck.

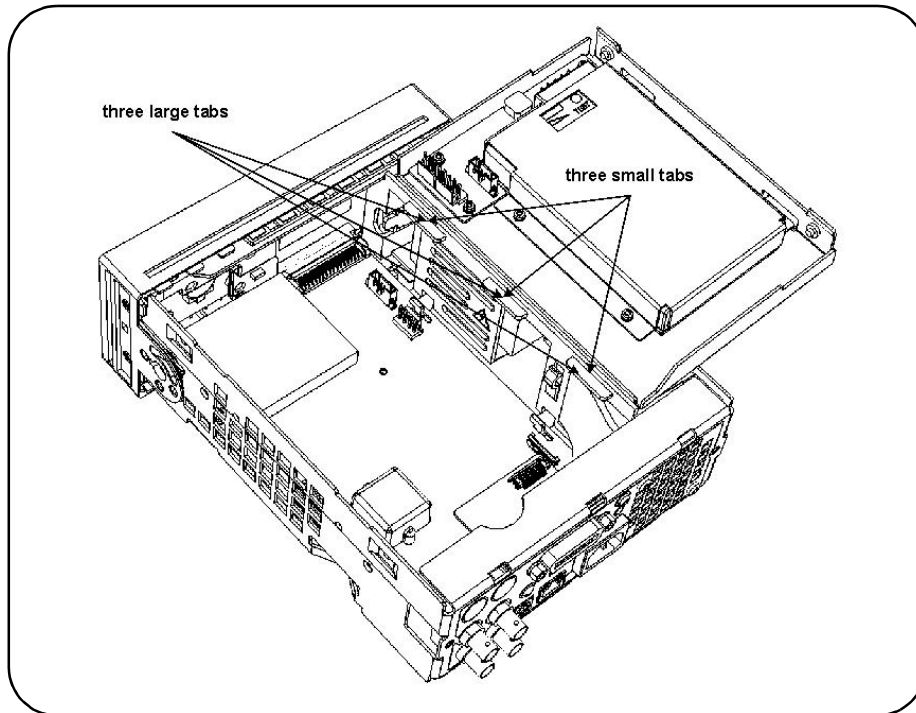

Figure 3. Temporarily Moving the Internal Battery (Option 300).

Moving the Optional Channel Assembly (Option 106)

When installing options it may be necessary to temporarily move 53210A Option 106 or 53220A/53230A Option 106 for easier access. To move the optional channel if installed:

1. Remove the T20 TORX screw and lockwasher at the rear end of the Option 106/115 aluminum deck.
2. Remove the two flathead screws that secure the assembly to the side panel.

3. Using a 5/16" open end wrench, loosen the SMA connector on the end of the semi-rigid cable that is connected to the PC board.
4. Slide the Option 106/115 assembly to the rear of the chassis, as necessary, to expose the two gold-connectors at the front of the motherboard near the front panel (J101 and J201).

Ultra-High Stability Timebase (Option 010)

NOTE

Option 010 (Ultra-High Stability Timebase) must be performed by technicians at an Agilent Technologies Service Center. Go to www.agilent.com/find/assist for information on contacting Agilent in your region, or contact your Agilent Technologies Representative.

NOTE

To order the Ultra-High Stability Option 010, you will need to place an order with Agilent for 53200U-010 and identify which counter you have (Agilent 53210A, 53220A, or 53230A).

GPIB Interface (Option 400)

Option 400 GPIB Connector Parts (53200U - 400)

Item	Agilent Part No.	Qty.
• PC Board Assembly	P0001-63001	1
• Ribbon Cable, 16-pin	53200-61601	1
• 7mm Hex-head standoff	0380-0644	2
• Washer, lock	2190-0577	2

Preliminary Steps

CAUTION

Before proceeding with the installation, follow all the ESD steps as outlined in the section titled "Do This First" at the beginning of this document.

1. Remove the cover and rear bezel as described under “**Removing the Cover and Rear Bezel**” at the beginning of this document.
2. If installed, temporarily move the Option 300 internal battery as described under “**Moving the Internal Battery (Option 300)**” at the beginning of this document.

Procedure

1. Remove the GPIB Cover Plate using a T20 TORX screwdriver.
2. Insert the GPIB Connector through the connector hole on the rear panel.
3. Use a 7mm spin-tite to install the two supplied Hex-head standoffs and lock washers. Tighten the two standoffs securely (do not over-tighten).
4. Connect one end of the supplied 16-pin ribbon cable to connector J901 on the motherboard chassis.

NOTE

Be sure the non-insulated side of the pins on the cable is facing the pins in the motherboard connector to provide electrical contact.

5. Connect the other end of the ribbon cable to J1 on the GPIB PCB assembly.
6. Re-install the Option 300 Internal Battery (if moved). Be sure to re-connect any disconnected cables.
7. Re-install the cover, rear bezel, and handle (if applicable).

Internal Battery DC Power (Option 300)

Option 300 Battery Pack Parts (53200U - 300)

Item	Agilent Part No.	Qty.
• Battery charger PCB Assembly	53200-66507	1
• Battery	1420-0909	1
• Y-Cable	53200-61602	1
• Ribbon cable, 6-pin	53200-61603	1
• Deck	53200-00601	1
• Cover	53200-00602	1
• TORX 10 screws	0515-0430	7
• TORX 20 screws	0515-0433	2

Preliminary Steps

CAUTION

Before proceeding with the installation, follow all the ESD steps as outlined in the section titled "Do This First" at the beginning of this document.

1. Remove the cover and rear bezel as described under "**Removing the Cover and Rear Bezel**" at the beginning of this document.

Procedure

1. Using a medium slot-head screwdriver, gently push back the 4-pin connector lock tab on the motherboard end of the jumper cable that connects between the Motherboard (J1000) and the PowerSupply board (J2). Refer to Figures 4 and 5.

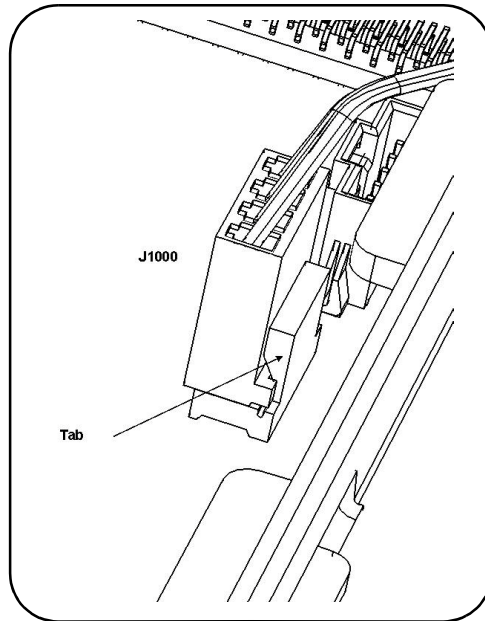

Figure 4. Connector Locking Tab

2. Gently move the cable 4-pin connector side-to-side while pulling upward on the cable connector until the jumper cable is free from the motherboard.

3. Repeat steps 1 and 2 for the other end of the jumper cable where it connects to the AC power supply assembly (6-pin connector) on the side wall of the instrument. See Figure 5. Set the jumper cable aside in a safe location in case it is needed in the future.

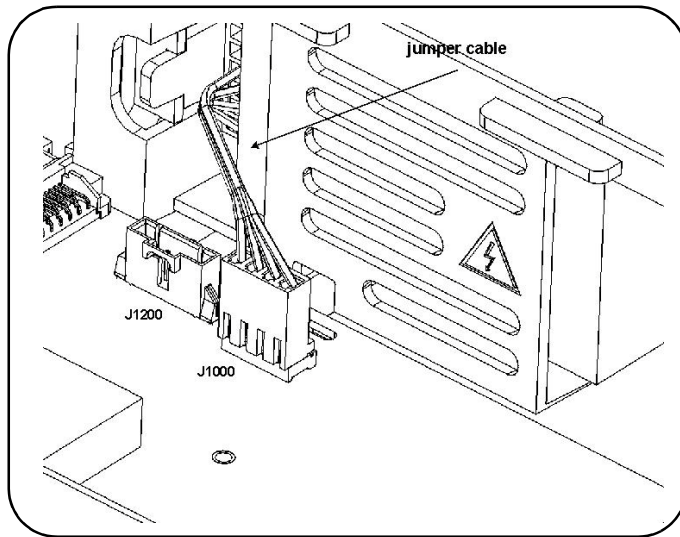

Figure 5. Jumper Cable Installed.

4. Next, connect the 6-pin connector on the supplied Y-cable assembly (Figure 6) to the AC power supply 6-pin connector, and then connect the 4-pin connector on the cable to the motherboard 4-pin connector where the jumper cable was removed in step 2.

5. Be sure the locking tabs on the PC board connectors lock the cable connectors at each end, preventing the cable connectors from working loose on their own.

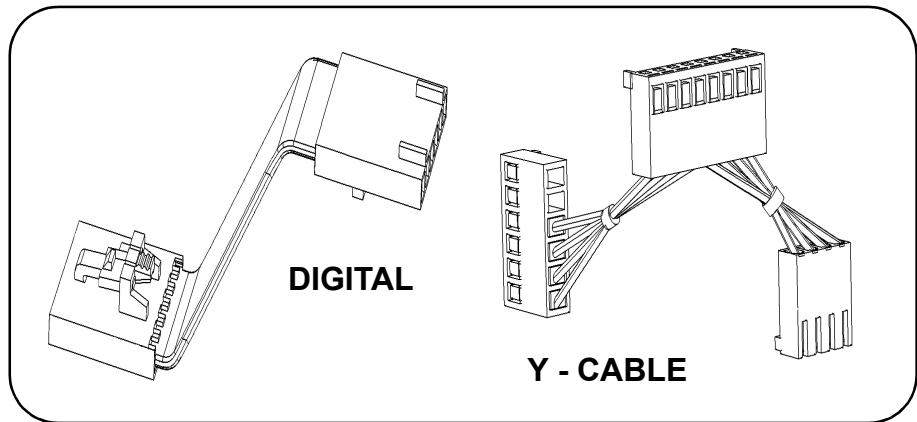

Figure 6. Digital and Y-Cables.

6. Connect one end of the supplied (digital) 6-pin ribbon cable (Figure 6) to the 6-pin connector J1200 (next to 4-pin connector J1000 on the motherboard).
7. On the Battery assembly, push and hold the white test button while observing the charge-level indicator (Figure 7). The charge level should be at least 25%. It should charge to 100% after installation when AC power is applied.

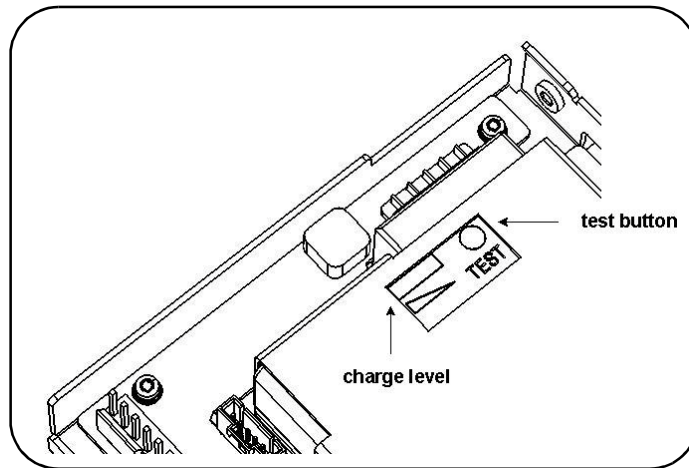

Figure 7. Test Button and Charge Indicator.

8. Set the Battery assembly on its back on the right-hand side of the chassis and insert the three small plastic tabs on the chassis into the three slots on the assembly deck. Connect the two cables (just installed) to the battery charger assembly 6-pin (J101) and 8-pin (J100) PC board connectors. (Figure 8).

NOTE

Be sure the lock tabs on the PC board connectors lock the cable connectors at their ends, preventing the cable connectors from working loose on their own.

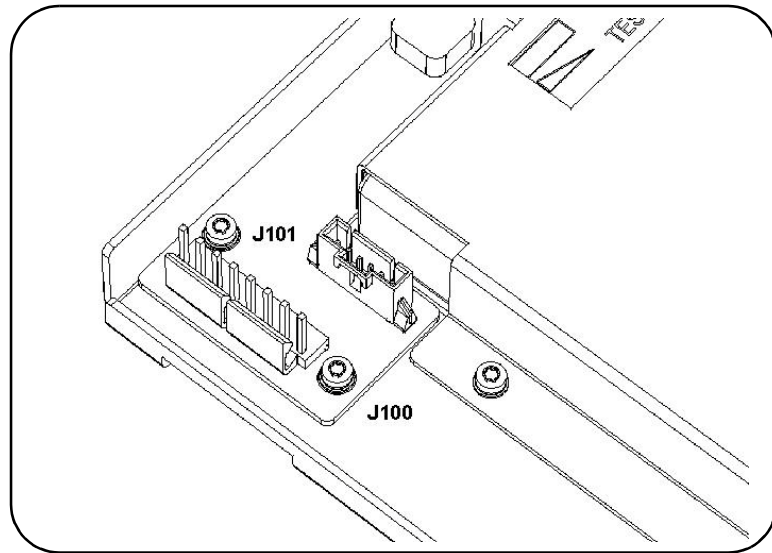

Figure 8. Battery Assembly Connectors.

9. Move the whole assembly from the three small tabs and insert the three large tabs on the plastic AC power supply cover into the three slots on the battery assembly deck shown in Figure 9. Press the opposite side of the battery assembly down until the two tabs on the battery assembly deck rest in the the cutouts of the chassis side panel.

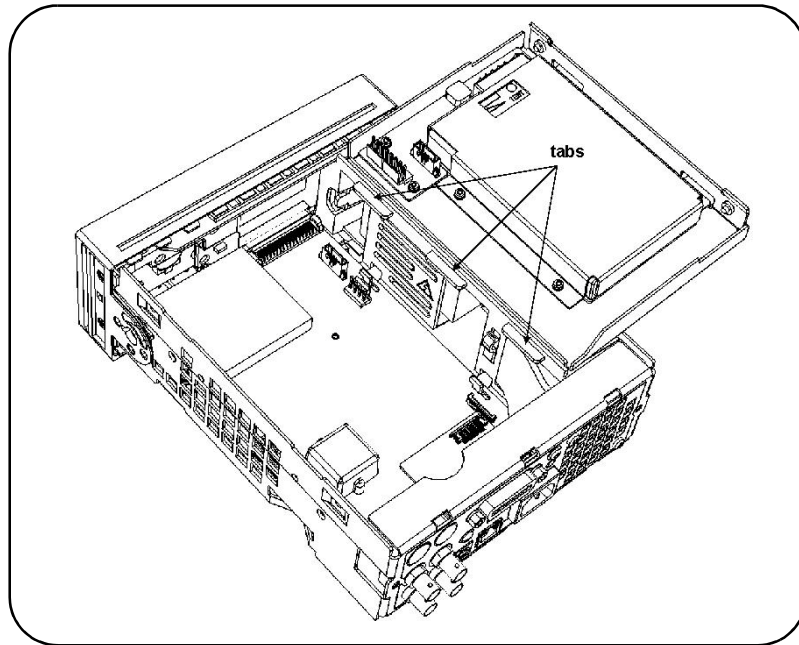

Figure 9. Battery Assembly Held By Three Small Tabs.

10. Install the supplied TORX T20 screws and lockwashers (2 each) through the provided chassis holes into the imbedded nuts in the battery deck and secure.
11. Re-install the cover, rear bezel, and handle (if applicable).

53210A/53220A/53230A Rear Panel Parallel Inputs (Option 201)

Installation of Option 201 (Rear Panel Parallel Inputs) must be performed by technicians at an Agilent Technologies Service Center. **The purchase of this option (53200U-201) includes the cost of Agilent installing the option and verifying that the instrument is operating correctly.** You must send your instrument and the option kit to Agilent for installation to occur.

Obtaining Installation Service (worldwide)

To arrange for option installation, contact Agilent Technologies at one of the following telephone numbers:

- United States:(800) 829-4444
- Europe: 31 20 547 2111
- Japan: 0120-421-345

For other locations, go to www.agilent.com/find/assist or contact your Agilent Technologies Representative. The Service Center will provide information on how to ship the instrument and the option kit to the center for installation.

Repackaging for Shipment

In preparation for shipment to Agilent, be sure to:

1. Attach a tag to the instrument identifying the owner and indicating the required installation (Option 201). Include the model number and full serial number on the tag.
2. Retain all loose accessories, power cords, CDs, manuals, and the like. Only ship the instrument and the option kit.
3. Place the instrument and the option kit in the instrument's original

container with appropriate packaging material for shipping.

4. Secure the container with strong tape or metal bands.

If the original shipping container is not available, place the instrument in a container which will ensure at least 10 cm (4 inches) of compressible packaging material around all sides of the instrument. Use static-free packaging materials to avoid damage. *Agilent suggests that you always insure shipments.*

53210A Channel 2 Front Panel Input (Option 106 and Option 202)

Option 106/202 Channel 2 Parts (53200U - 106)

Item	Agilent Part No.	Qty.
• 6.0 GHz PC Assembly	53200-67505	1
• Ribbon Cable, 40-pin	53200-61605	1
• Labels, 6 GHz	53200-84301	2
• Bracket, Aluminum	53200-00603	1
• TORX 10 screws	0515-0430	4
• Screws, Flathead	0515-1946	2
• TypeN-to-SMA Connector-Adapter	E4418-20009	1
• RF Cable, Front, SMA Semi-rigid	53200-61612	1
• Washer Plate (with "LIFT" tab)	E4418-00016	1
• 14mm Hex Nut	2950-0132	1

Preliminary Steps

CAUTION

Before proceeding with the installation, follow all the ESD steps as outlined in the section titled "Do This First" at the beginning of this document.

1. Remove the cover and rear bezel as described under "**Removing the Cover and Rear Bezel**" at the beginning of this document.
2. If installed, temporarily move the Option 300 internal battery as described under "**Moving the Internal Battery (Option 300)**" at the beginning of this document.
3. Assemble the parts in the Option 106/115 package as follows (Figure 10):
 - Position the A3 PC board over the aluminum bracket so that the SMA edge connector is pointed toward the front flange (without the hole) and sits on top of the standoffs.
 - Install the 4 (Option 106) T10 TORX screws to secure the PC board to the aluminum deck.

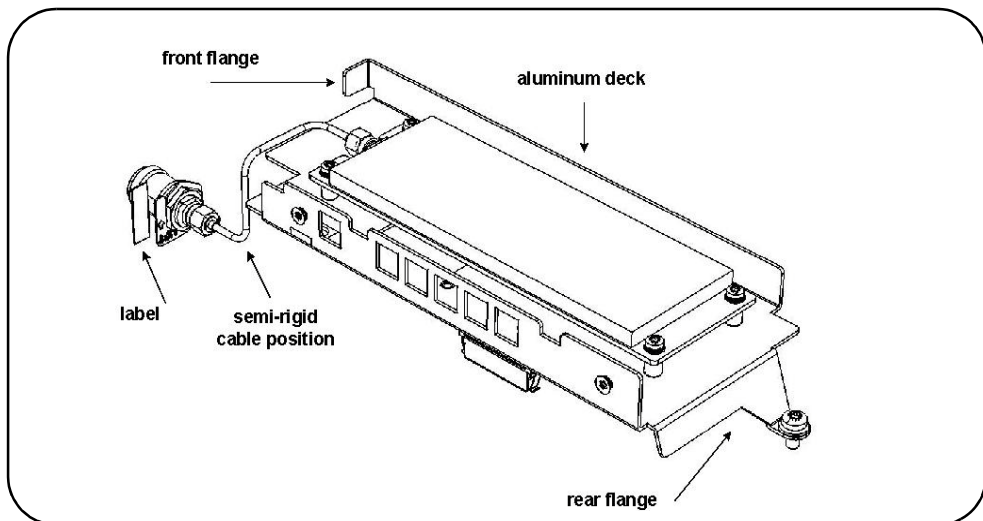

Figure 10. 53210A Channel 2 Front Panel Option 106/202.

Channel 2 Front Panel Installation Procedure (53210A)

1. Remove the front panel assembly as follows:

NOTE

Read each instruction step in its entirety, while examining the hardware and referring to the appropriate figure(s), before proceeding with the step. This will acquaint you completely, in advance, with the action to be performed. The actions in some steps must be accomplished simultaneously to succeed. Read all nearby NOTES carefully.

2. Turn the chassis upside down. On the bottom of the motherboard, remove the T10 TORX screw that secures the smaller P500 Processor board to the motherboard (see Figure 11; for illustration purposes only, the P500 board is shown with plastic support bracket removed).

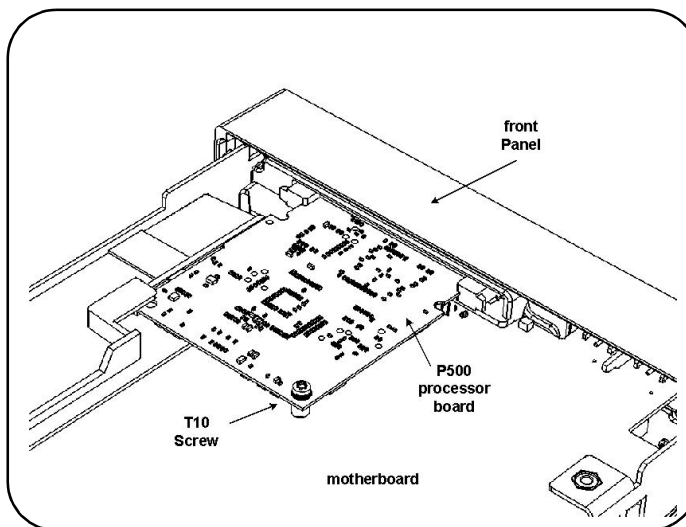

Figure 11. P500 Processor Board.

3. Note how the left rear corner of the P500 board fits into its slot (above the small plastic standoff inside the slot) to hold the board horizontal. Press the two tabs securing the edge connector of the PC board to release the PC board.
4. Remove the P500 board carefully from its connector and set it aside in a safe location on the ESD mat.
5. Turn the counter chassis upright and position the rear panel facing you as shown in Figure 12.
6. Remove the T20 TORX screw on the front left-hand side of the A1 motherboard as shown in Figure 12.

NOTE

The four standoffs on the aluminum side panels (two on each side, front) secure the front panel into the four holes cut out on the plastic sides of the front panel (two on each side). The next steps free the standoffs from the holes so the front panel can be removed.

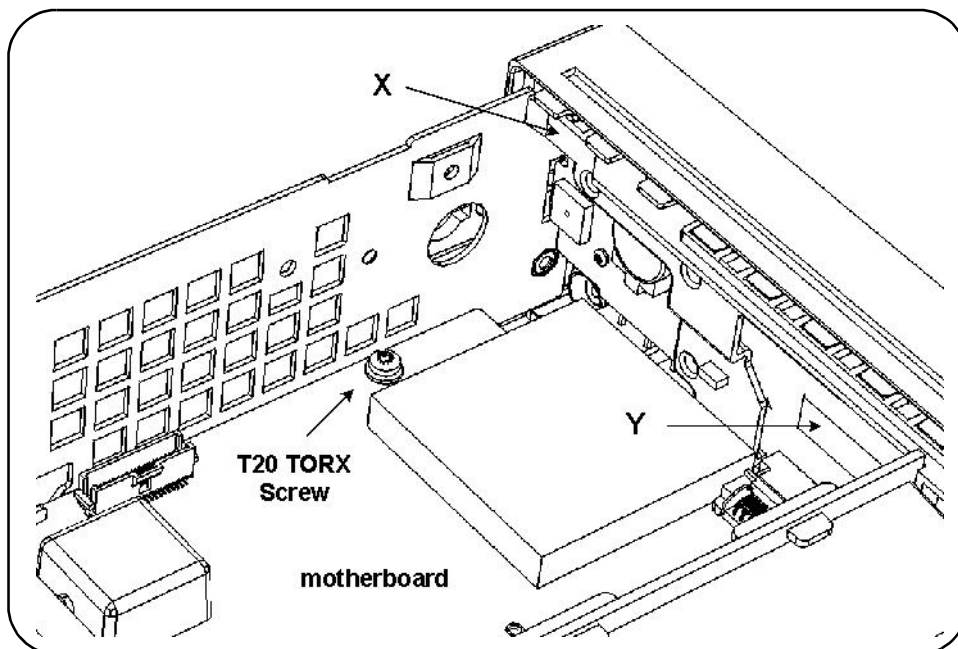

Figure 12. T20 TORX Screw on Motherboard.

7. With your right hand, press in on the plastic tab (X on Figure 12) at the top left front of the front panel, while at the same time, use your left hand to press in on the front of the left-hand aluminum chassis side-panel, so that the front of the side-panel overlaps the depressed tab and keeps it depressed. The left front standoffs should now be free of their holes.

8. On the middle front right-hand side of the front panel, pull the plastic tab (Y on Figure 12) carefully toward the rear of the chassis and simultaneously press in the right side panel of the aluminum chassis until the front panel is partially released. The right front standoffs should now be free of their holes.

NOTE

At this point, the front panel is only held to the A1 motherboard by an edge connector.

9. Using gentle pressure on both sides of the front panel, push the front panel away from the motherboard to release the edge connector and free the front panel completely.

10. Insert the typeN-to-SMA connector-adapter into the Channel 2 hole on the front panel (remove the hole-plug, if necessary), so that the typeN connector is on the front side of the front panel.

11. On the back side of the connector-adapter, place the washer plate and the 14mm hex nut over the SMA connector and secure. See Figure 13.

NOTE

Make sure the word "LIFT" is visible on the washer-plate and that the "LIFT" tab on the washer-plate is not underneath the hex nut.

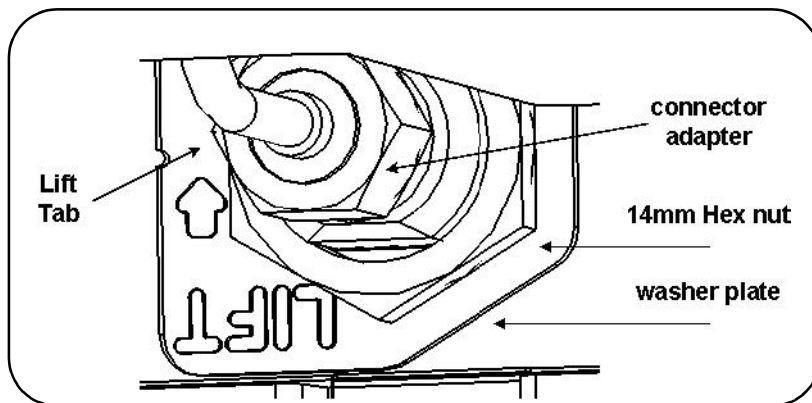

Figure 13. Connector-Adapter Installation.

12. Pull up slightly on the "LIFT" tab on the washer-plate so that the tab blocks the hex nut from coming unscrewed after installation.

13. Connect the supplied semi-rigid cable to the SMA connector on the connector-adaptor. Finger-tighten the connector so that the cable is positioned to connect to the Channel 2 assembly as shown in Figures 10 and 14. Do not tighten the nut with a wrench yet.

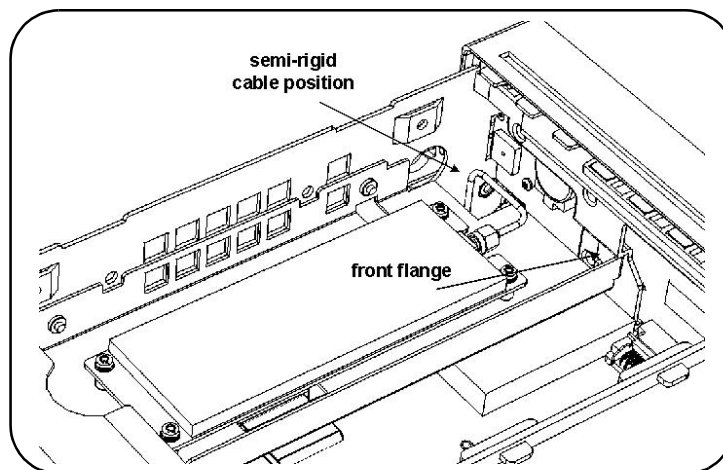

Figure 14. Semi-rigid Cable Position.

14. Re-install the front panel as follows:

NOTE

Carefully guide the semi-rigid cable into the chassis through the opening provided while installing the front panel onto the motherboard.

15. Line up the edge connector pins on the motherboard with the edge connector on the front panel and carefully press the front panel onto the motherboard.

NOTE

The four standoffs on the aluminum side panels (two on each side) must lock into the four holes cut out on the plastic sides of the front panel (two on each side).

NOTE

Be sure that the right-hand side tab (see step 8 above) locks the side panel in place. It may be necessary to gently press outward on the right-hand side panel until the tab locks into place.

16. Re-install the T20 TORX screw removed in step 6 above.

17. Re-install the P500 Processor board on the underside of the motherboard (removed in steps 3 and 4 above) as follows (refer to Figure 11):

- Insert the rear left-hand corner of the PC board in the horizontal slot (as viewed from above) and then line up the edge connector pins on the PC board with the edge connector on the underside of the front panel.

NOTE

Verify that the PC board is parallel horizontally with the motherboard. The rear left-hand corner must sit on top of the small standoff inside the slot.

- Press in carefully on the rear edge of the PC board until the edge connector tabs lock into place.
- Install the T10 TORX screw through the hole in the P500 board into the standoff on the A1 motherboard (screw removed in step 2).

18. Turn the chassis upright. Install the Option 106 Channel 2 assembly as follows:

19. Remove the T20 TORX screw at the rear of the motherboard.

20. Connect one end of the supplied 40-pin ribbon cable to J900 on the motherboard. Connect the other end to J401 on the underside of the Channel 2 assembly.

21. Set the Channel 2 assembly down on top of the motherboard so that the female SMA edge connector is near the male SMA connector of the semi-rigid cable installed on the front panel assembly (see Figure 15).

NOTE

The front flange on the right-front of the Channel 2 assembly bracket must rest on the tab protruding from the front panel (see Figure 15).

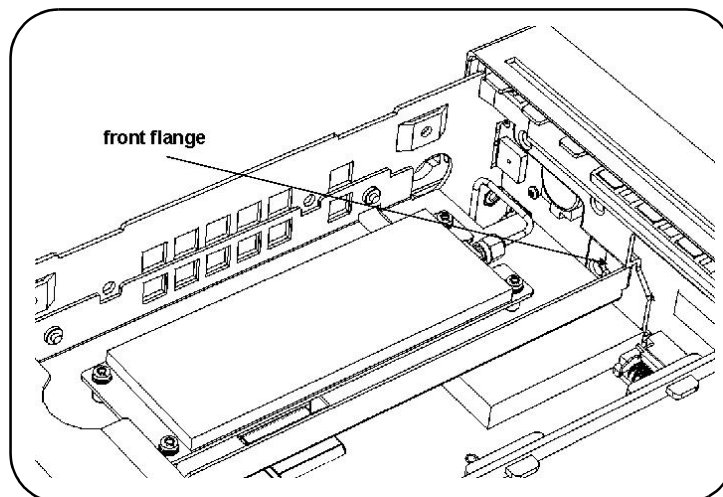

Figure 15. Front Flange Resting On Plastic Tab.

22. Line up the semi-rigid SMA cable male connector and the Channel 2 assembly SMA female edge connector, connect them together and loosely tighten the SMA connector.

NOTE

Be sure the flange on the front of the Channel 2 assembly remains positioned over the tab on the front panel assembly.

23. Re-install the T20 TORX screw removed in step 19 above, securing the rear flange on the Channel 2 bracket to the motherboard with the screw. Do not tighten the screw all the way down at this time.

NOTE

If necessary, turn the chassis over and, through the open area provided, loosen the SMA connector on the semi-rigid cable where it connects to the front panel and gently re-position the cable until it is positioned to connect the assembly to the front panel, with no stress on the semi-rigid cable.

24. Use a 5/16" open-end wrench to secure the two SMA connectors at each end of the semi-rigid cable. Do not overtighten.

25. Install the two supplied flathead screws through the holes in the left-hand aluminum side panel into the embedded nuts on the bracket of the Channel 2 assembly.

26. Tighten the T20 TORX screw (step 23 above).

27. Re-install the Option 300 Internal Battery (if moved). Be sure to re-connect any disconnected cables.

28. Re -install the cover, rear bezel, and handle (if applicable).

29. Install the supplied Option 106 label alongside the front panel typeN connector in the depression provided.

53210A Channel 2 Rear Panel Input (Option 106 and Option 203)

Option 106 Channel 2 Parts (53200U - 106)

Item	Agilent Part No.	Qty.
• 6.0 GHz PC Assembly	53200-67505	1
• Ribbon Cable, 40-pin	53200-61605	1
• Labels, 6 GHz	53200-84301	2
• Bracket, Aluminum	53200-00603	1
• TORX 10 screws	0515-0430	4
• Screws, Flathead	0515-1946	2
• 14 mm Hex Nut	2950-0132	1

Option 203 Rear Panel Channel 2 Parts 53200U - 203)

Item	Agilent Part No.	Qty.
• RF Cable, Rear, SMA Semi-rigid	53200-61613	1
• Retainer	53200-40002	1
• Plug Assembly	53200-40001	1
• Screw, Self-tapping	0515-5360	1

Preliminary Steps

CAUTION

Before proceeding with the installation, follow all the ESD steps as outlined in the section titled "Do This First" at the beginning of this document.

1. Remove the cover and rear bezel as described under “**Removing the Cover and Rear Bezel**” at the beginning of this document.

2. If installed, temporarily move the Option 300 internal battery as described under “**Moving the Internal Battery (Option 300)**” at the beginning of this document.

3. Assemble the parts in the Option 106 package as follows (Figure 16):

- Position the A3 PC board over the aluminum bracket so that the SMA edge connector is pointed toward the front flange (without the hole) and sits on top of the standoffs.
- Install the 4 (Option 106) T10 TORX screws to secure the PC board to the aluminum deck.

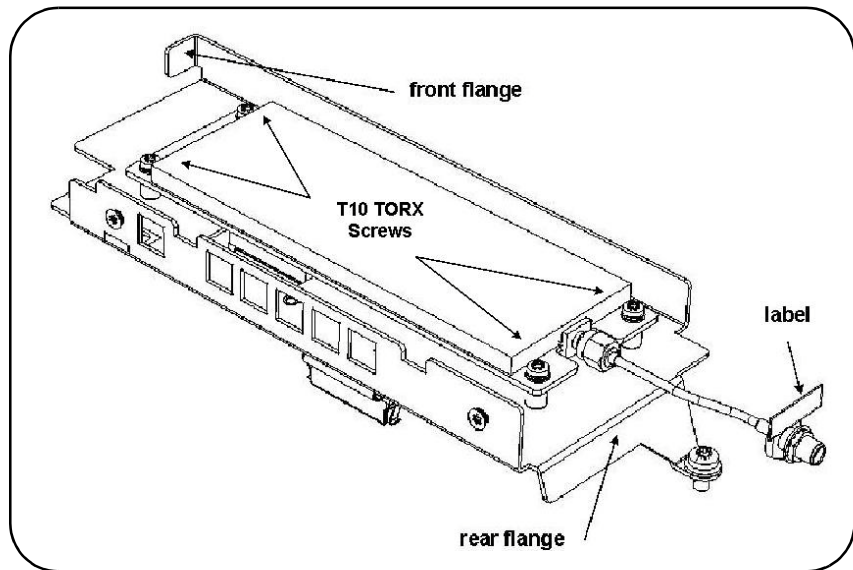

Figure 16. 53210A Channel 2 Rear Panel Option 106/203.

Channel 2 Rear Panel Installation Procedure (53210A)

1. Install the Channel 2 PC assembly as follows:
2. Remove the T20 TORX screw at the rear of the motherboard.

3. Connect one end of the supplied 40-pin ribbon cable to J900 on the motherboard. Connect the other end to J401 on the underside of the Channel 2 PC board assembly.

4. Set the Channel 2 assembly down on top of the motherboard so that the SMA edge connector is towards the rear panel. The front flange on the right-front of the Channel 2 assembly bracket must rest on the tab protruding from the front panel (see Figure 17).

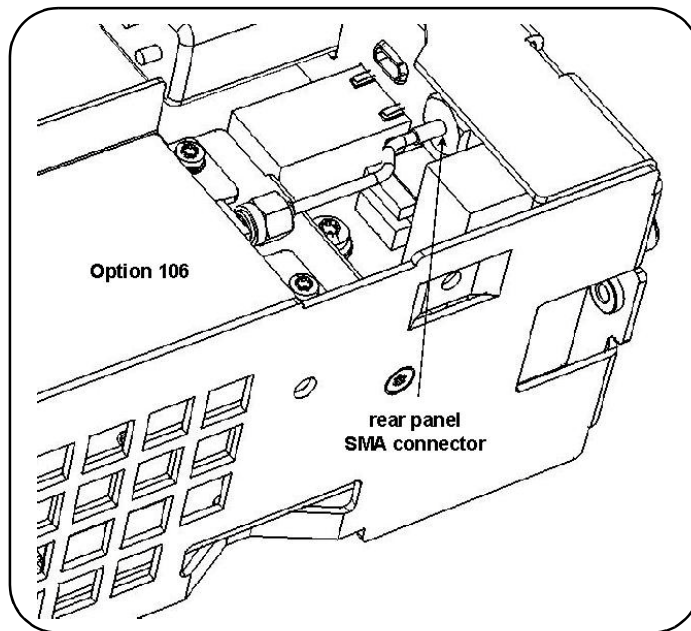

Figure 17. Channel 2 assembly with Rear Panel SMA Connector.

5. Re-install the T20 TORX screw removed in step 2 above, securing the rear flange on the Channel 2 bracket to the motherboard with the screw.

6. Install the two supplied flathead screws through the holes in the left-hand aluminum side panel into the embedded nuts on the bracket of the Channel 2 assembly.

7. Install the supplied SMA semi-rigid cable as follows:

- Insert the end of the supplied semi-rigid cable with the female SMA connector through the hole on the rear panel marked "Opt 106/115".
- Line up the male SMA cable connector on the other end of the semi-rigid cable and the Channel 2 assembly SMA edge connector, connect them together and tighten the SMA cable connector using a 5/16" wrench.
- Secure the rear panel SMA connector with the supplied 5/16" hex nut and lockwasher. Do not overtighten.

NOTE

Be sure there is no stress on the semi-rigid cable.

8. Re-install the Option 300 Internal Battery (if moved). Be sure to re-connect any disconnected cables.

9. Re -install the cover, rear bezel, and handle (if applicable).

10. Install the supplied Option 106 label above the rear panel SMA connector in the location provided.

53220A/53230A Channel 3 Front Panel Input (Options 106 and 202)

Option 106/202 Channel 3 Parts (53200U - 106)

Item	Agilent Part No.	Qty.
• 6.0 GHz PC Assembly	53200-67505	1
• Ribbon Cable, 40-pin	53200-61605	1
• Labels, 6 GHz	53200-84301	2
• Bracket, Aluminum	53200-00603	1
• TORX 10 screws	0515-0430	4
• Screws, Flathead	0515-1946	2
• TypeN-to-SMA Connector-Adapter	E4418-20009	1
• RF Cable, Front, SMA Semi-rigid	53200-61612	1
• Washer Plate (with "LIFT" tab)	E4418-00016	1
• 14mm Hex Nut	2950-0132	1

Preliminary Steps

CAUTION

Before proceeding with the installation, follow all the ESD steps as outlined in the section titled "Do This First" at the beginning of this document.

1. Remove the cover and rear bezel as described under "**Removing the Cover and Rear Bezel**" at the beginning of this document.
2. If installed, temporarily move the Option 300 internal battery as described under "**Moving the Internal Battery (Option 300)**" at the beginning of this document.
3. Assemble the parts in the Option 106/115 package as follows (Figure 18):

- Position the A3 PC board over the aluminum bracket so that the SMA edge connector is pointed toward the front flange (without the hole) and sits on top of the standoffs.
- Install the 4 (Option 106) T10 TORX screws to secure the PC board to the aluminum deck.

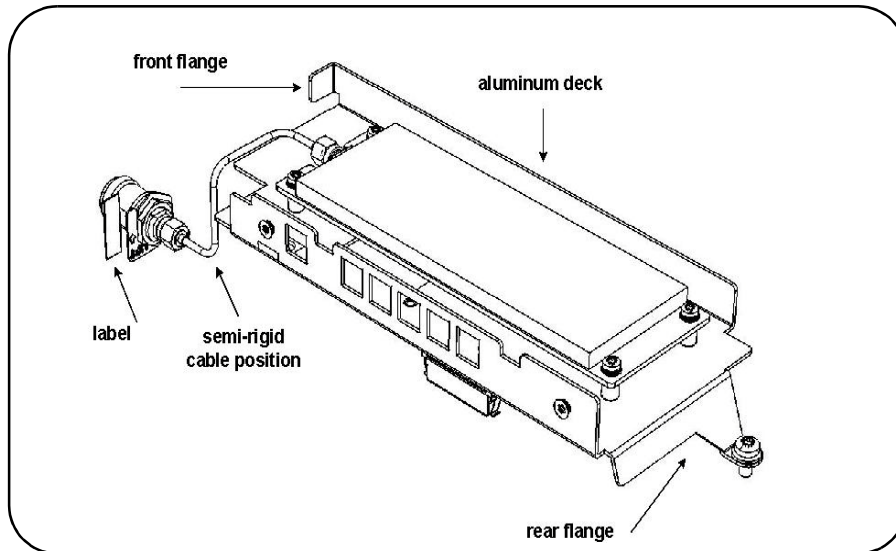

Figure 18. 53220A/53230A Option 106/202.

Channel 3 Front Panel Installation Procedure (Option 202)

1. Remove the front panel assembly as follows:

NOTE

Read each instruction step in its entirety, while examining the hardware and referring to the appropriate figure(s), before proceeding with the step. This will acquaint you completely, in advance, with the action to be performed. The actions in some steps must be accomplished simultaneously to succeed. Read all nearby NOTES carefully.

2. Turn the chassis upside down. On the bottom of the motherboard, remove the T10 TORX screw that secures the smaller P500 Processor board to the motherboard (see Figure 19; for illustration purposes only, the P500 board is shown with plastic support bracket removed).

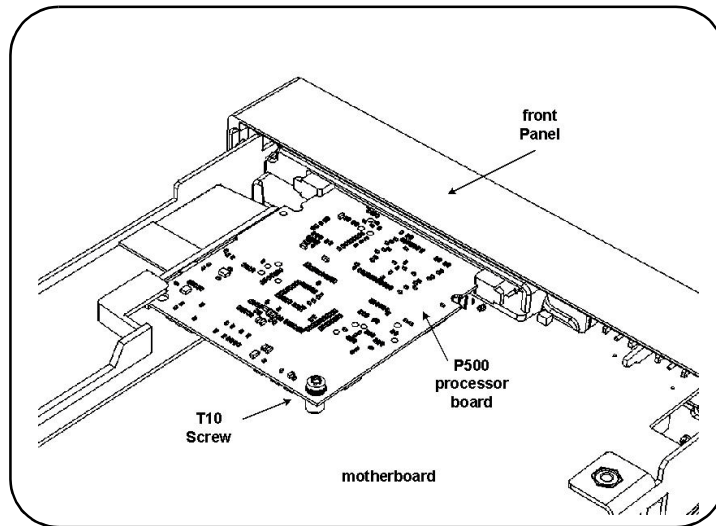

Figure 19. P500 Processor Board.

3. Note how the left rear corner of the P500 board fits into its slot (above the small plastic standoff inside the slot) to hold the board horizontal. Press the two tabs securing the edge connector of the PC board to release the PC board.

4. Remove the P500 board carefully from its connector and set it aside in a safe location on the ESD mat.

5. Turn the counter chassis upright and position the rear panel facing you as shown in Figure 20.

6. Remove the T20 TORX screw on the front left-hand side of the A1 motherboard as shown in Figure 20.

NOTE

The four standoffs on the aluminum side panels (two on each side, front) secure the front panel into the four holes cut out on the plastic sides of the front panel (two on each side). The next steps free the standoffs from the holes so the front panel can be removed.

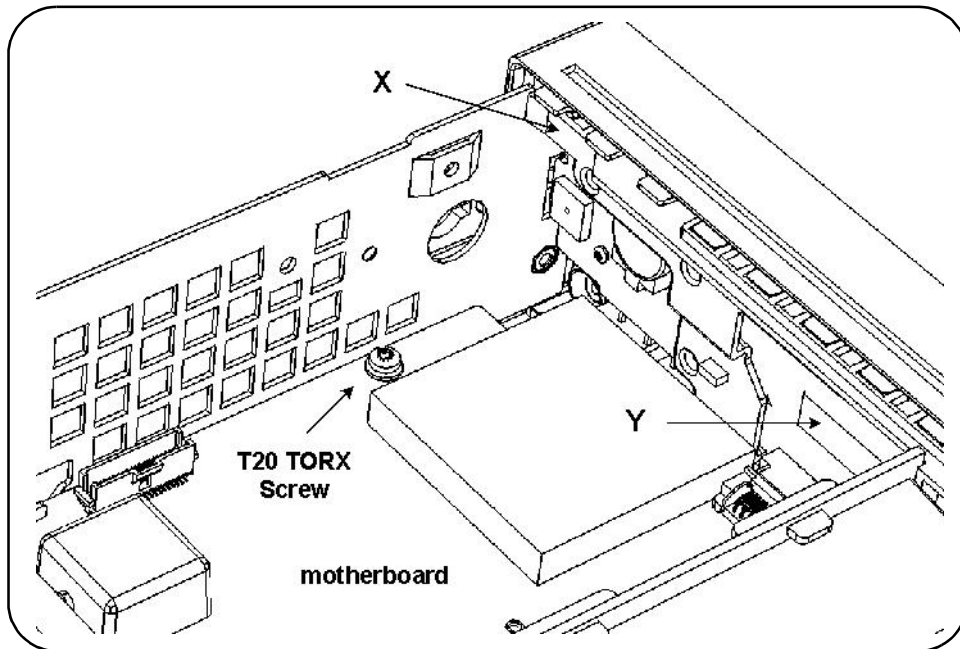

Figure 20. T20 TORX Screw on Motherboard.

7. With your right hand, press in on the plastic tab (X on Figure 20) at the top left front of the front panel, while at the same time, use your left hand to press in on the front of the left-hand aluminum chassis side-panel, so that the front of the side-panel overlaps the depressed tab and keeps it depressed.

8. On the middle front right-hand side of the front panel, pull the plastic tab (Y on Figure 20) carefully toward the rear of the chassis and simulta-

neously

press in the right side panel of the aluminum chassis until the front panel is partially released.

NOTE

At this point, the front panel is only held to the A1 motherboard by an edge connector.

9. Using gentle pressure on both sides of the front panel, push the front panel away from the motherboard to release the edge connector and free the front panel completely.

10. Insert the typeN-to-SMA connector-adapter into the Channel 3 hole on the front panel (remove the hole-plug, if necessary), so that the typeN connector is on the front side of the front panel.

11. On the back side of the connector-adapter, place the washer plate and the 14mm hex nut over the SMA connector and secure. See Figure 21.

NOTE

Make sure the word "LIFT" is visible on the washer-plate and that the "LIFT" tab on the washer-plate is not underneath the hex nut.

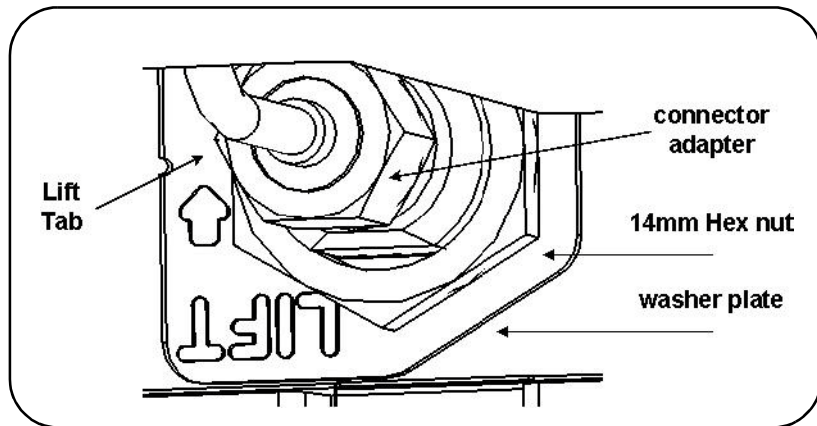

Figure 21. Connector-Adapter Installation.

12. Pull up slightly on the "LIFT" tab on the washer-plate so that the tab blocks the hex nut from coming unscrewed after installation.

13. Connect the supplied semi-rigid cable to the SMA connector on the connector-adapter. Finger-tighten the connector so that the cable is positioned to connect to the Channel 3 assembly as shown in Figures 18 and 22. Do not tighten the nut with a wrench yet.

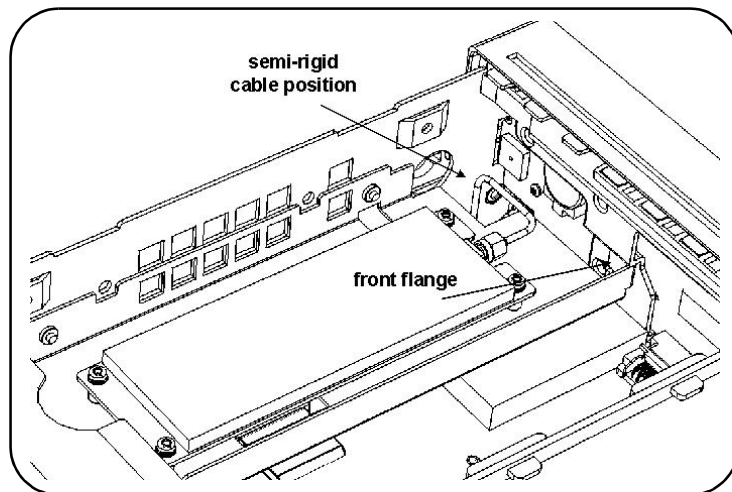

Figure 22. Semi-rigid Cable Position.

14. Re-install the front panel as follows:

NOTE

Carefully guide the semi-rigid cable into the chassis through the opening provided while installing the front panel onto the motherboard.

15. Line up the edge connector pins on the motherboard with the edge connector on the front panel and carefully press the front panel onto the motherboard.

NOTE

The four standoffs on the aluminum side panels (two on each side) must lock into the four holes cut out on the plastic sides of the front panel (two on each side).

NOTE

Be sure that the right-hand side tab (see step 8 above) locks the side panel in place. It may be necessary to gently press outward on the right-hand side panel until the tab locks into place.

16. Re-install the T20 TORX screw removed in step 6 above to lock the left-hand side panel in place.

17. Re-install the P500 Processor board on the underside of the motherboard (removed in steps 3 and 4 above) as follows.

18. Insert the rear left-hand corner of the PC board in the horizontal slot (as viewed from above) and then line up the edge connector pins on the PC board with edge connector on the underside of the front panel.

NOTE

Verify that the P500 processor board is parallel horizontally with the A1 motherboard. The rear left-hand corner must sit on top of the small standoff inside the slot.

19. Press in carefully on the rear edge of the P500 board until the edge connector tabs lock into place.

20. Install the T10 TORX screw through the hole in the PC board into the standoff on the motherboard (screw removed in step 2 above).
21. Turn the chassis upright. Install the Channel 3 PC assembly as follows:
22. Remove the T20 TORX screw at the rear of the motherboard.
23. Connect one end of the supplied 40-pin ribbon cable to J900 on the motherboard. Connect the other end to J401 on the underside of the Channel 3 circuit board.
24. Set the Channel 3 assembly down on top of the motherboard so that the female SMA edge connector is near the male SMA connector of the semi-rigid cable installed on the front panel assembly.
25. Line up the male semi-rigid SMA cable connector and the Channel 3 assembly female SMA edge connector, connect them together and loosely tighten the SMA connector.

NOTE

Be sure the flange on the front of the Channel 3 assembly is positioned over the tab on the front panel assembly. Refer to Figure 22.

26. Re-install the T20 TORX screw removed in step 23 above, securing the rear flange on the Channel 3 bracket to the motherboard with the screw. Do not tighten the screw all the way down at this time.

NOTE

If necessary, turn the chassis over and, through the open area provided, loosen the SMA connector on the semi-rigid cable where it connects to the front panel and carefully re-position the cable until it connects the assembly to the front panel, with no stress on the semi-rigid cable.

27. Use a 5/16" open-end wrench to secure the two SMA connectors at each end of the semi-rigid cable. Do not overtighten.

28. Tighten the T20 TORX screw (step 26 above).
29. Install the two supplied flathead screws through the holes in the left-hand aluminum side panel into the embedded nuts on the bracket of the Channel 3 assembly.
30. Re-install the Option 300 Internal Battery (if moved). Be sure to re-connect any disconnected cables.
31. Re -install the cover, rear bezel, and handle (if applicable).
32. Install the supplied Option 106 label alongside the front panel typeN connector in the area provided.

53220A/53230A Channel 3 Rear Panel Input (Options 106 and 203)

Option 106 Channel 3 Parts (53200U - 106)

Item	Agilent Part No.	Qty.
• 6.0 GHz PC Assembly	53200-67505	1
• Ribbon Cable, 40-pin	53200-61605	1
• Labels, 6 GHz	53200-84301	2
• Bracket, Aluminum	53200-00603	1
• TORX 10 screws	0515-0430	4
• Screws, Flathead	0515-1946	2
• 14 mm Hex Nut	2950-0132	1

Option 203 Rear Panel Channel 3 Parts 53200U - 203)

Item	Agilent Part No.	Qty.
• RF Cable, Rear, SMA Semi-rigid	53200-61613	1
• Retainer	53200-40002	1
• Plug Assembly	53200-40001	1
• Screw, Self-tapping	0515-5360	1

Preliminary Steps

CAUTION

Before proceeding with the installation, follow all the ESD steps as outlined in the section titled "Do This First" at the beginning of this document.

1. Remove the cover and rear bezel as described under “**Removing the Cover and Rear Bezel**” at the beginning of this document.

2. If installed, temporarily move the Option 300 internal battery as described under “**Moving the Internal Battery (Option 300)**” at the beginning of this document.

3. Assemble the parts in the Option 106 package as follows (Figure 23):

- Position the A3 PC board over the aluminum bracket so that the SMA edge connector is pointed toward the front flange (without the hole) and sits on top of the standoffs.
- Install the 4 (Option 106) T10 TORX screws to secure the PC board to the aluminum deck.

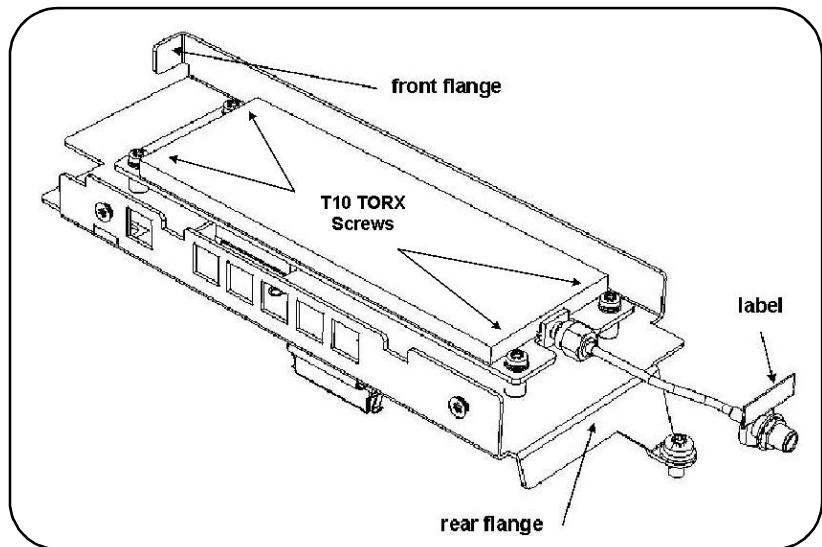

Figure 23. 53220A/53230A Channel 3 Rear Panel Option 106/203.

Channel 3 Rear Panel Installation Procedure (53220A/53230A)

1. Install the Channel 3 assembly assembly as follows:
2. Remove the T20 TORX screw at the rear of the motherboard.
3. Connect one end of the supplied 40-pin ribbon cable to J900 on the

motherboard. Connect the other end to J401 on the underside of the Channel 3 board.

4. Set the Channel 3 assembly down on top of the motherboard so that the SMA edge connector is towards the rear panel. The front flange on the right-front of the Channel 3 assembly bracket must rest on the tab protruding from the front panel (see Figure 24).

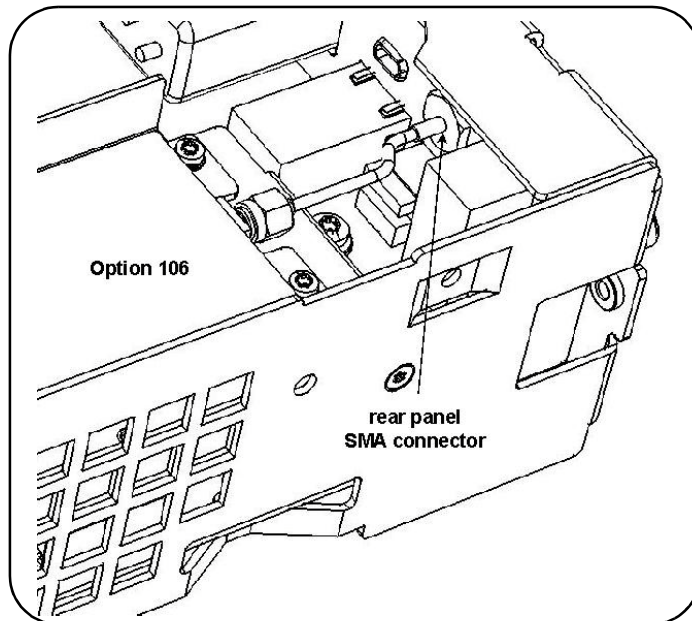

Figure 24. Channel 3 Assembly with Rear Panel SMA Connector.

5. Install the supplied SMA semi-rigid cable as follows:

6. Insert the end of the semi-rigid cable with the female SMA connector through the hole on the rear panel marked "Opt 106/115". Secure the connector with the supplied 5/16" hex nut and lockwasher. Finger-tighten only.

7. Line up the male SMA cable connector on the semi-rigid cable and the Channel 3 assembly female SMA edge connector, connect them together

and tighten both of the SMA connectors using a 5/16" wrench.

NOTE

If necessary, loosen the hex nut on the other end of the semi-rigid cable to align the cable and then tighten all nuts. There should be no stress on the semi-rigid cable.

8. Re-install the T20 TORX screw removed in step 2 above, securing the rear flange on the Channel 3 bracket to the motherboard with the screw.

9. Install the two supplied flathead screws through the holes in the left-hand aluminum side panel into the embedded nuts on the bracket of the Channel 3 assembly.

10. Re-install the Option 300 Internal Battery (if moved). Be sure to re-connect any disconnected cables.

11. Re -install the cover, rear bezel, and handle (if applicable).

12. Install the supplied Option 106 label above the rear panel SMA connector in the location provided.

53230A Option 150 (Pulse Microwave Measurements)

NOTE

Option 150 is an internal firmware upgrade to the 53230A. There are no parts associated with this option. However, this option requires that the 53230A has either Channel 3 Option 106 (6.0 GHz) or Option 115 (15.0 GHz) installed.

NOTE

Option 150 may be obtained by ordering 53230U-150 from your nearest Agilent Technologies Sales Office. Refer to the list of Sales and Service offices in the Appendix for the sales office nearest to you.
