

## Step-Down High Brightness Controller with Wide Input Voltage

### General Description

The FP7130 is a highly efficient step-down controller for powering high-brightness LEDs with a 6V to 80V input. It utilizes a hysteretic control architecture that accurately regulates LED current through external feedback and has a low 200mV average feedback voltage that reduces power loss and enhances converter efficiency. PWM and analog dimming are both available through the DIM pin, and it comes in an SOT23-6L package.

### Features

- Wide input voltage range: 6V to 80V
- Up to 1MHz switching frequency
- High-side adjustable current sense
- PWM and Analog dimming
- Thermal shutdown
- Open and short circuit protection
- 0.1kHz~32kHz PWM dimming frequency

### Applications

- DC/DC LED driver applications
- Desk lights and room lighting
- MR16 LED spotlight
- LED backlighting
- Constant-current regulators
- RGB LED applications

### Typical Application Circuit

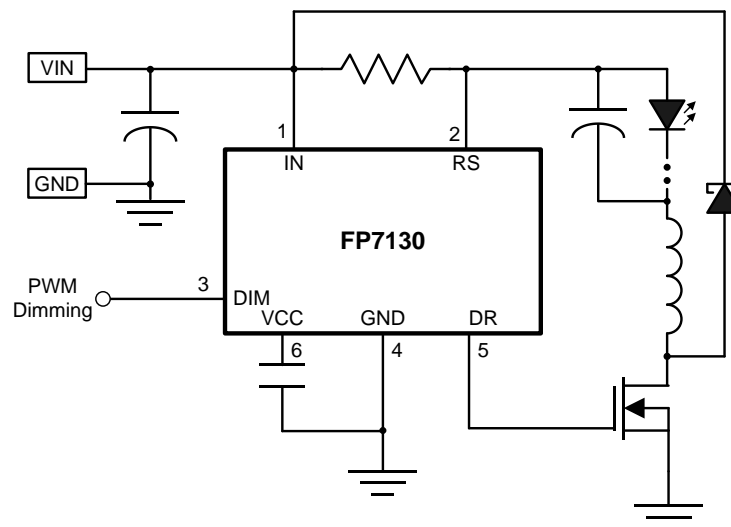

This datasheet contains new product information. Advanced Analog Technology reserves the rights to modify the product specification without notice. No liability is assumed as a result of the use of this product. No rights under any patent accompany the sales of the product.

**Step-Down High Brightness Controller with Wide Input Voltage**

**Function Block Diagram**

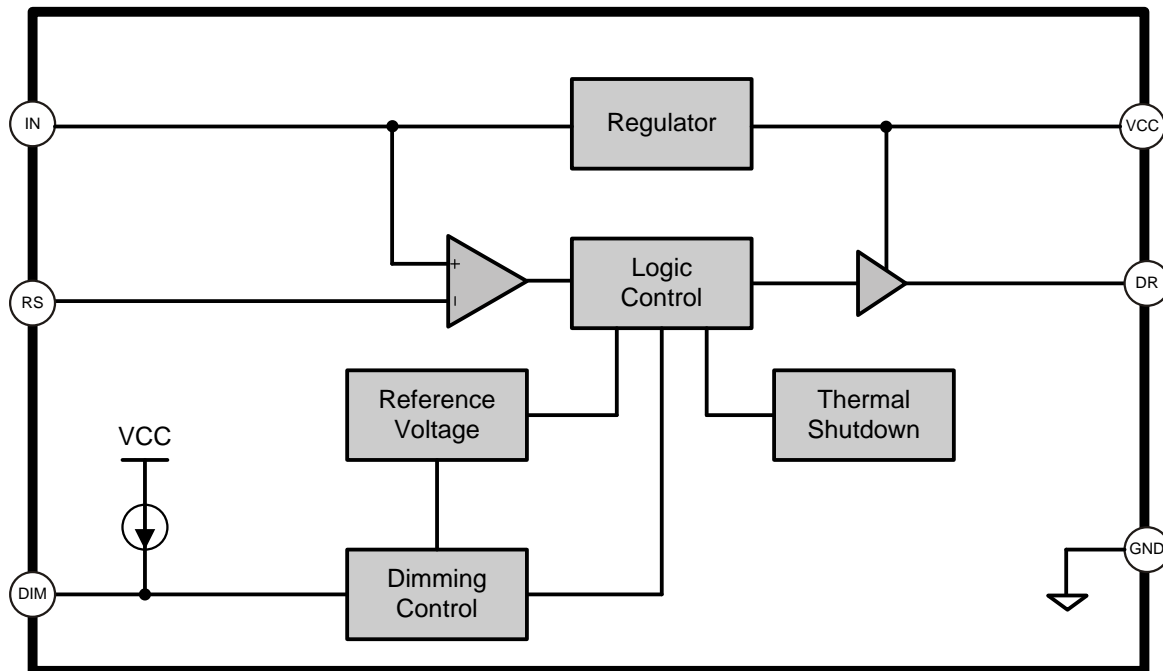

**Pin Descriptions**

**SOT23-6L**

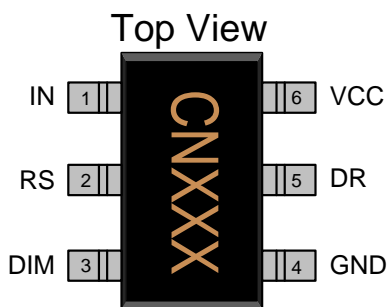

Name	No.	I / O	Description
IN	1	I/P	Connect a decoupling capacitor from the IN pin to GND, to serve as input supply pin
RS	2	I	Connect a current-sense resistor to the IN pin, to sense and regulate the average LED current.
DIM	3	I	Use this pin as input for Enable/Dimming command.
GND	4	P	Connect to GND for grounding all internal circuitry.
DR	5	O	This pin serves as the GATE driver output for an external N-channel power MOSFET.
VCC	6	P	Connect a 1uF decoupling capacitor from this pin to GND, as it is the output of the internal regulator.

This datasheet contains new product information. Advanced Analog Technology reserves the rights to modify the product specification without notice. No liability is assumed as a result of the use of this product. No rights under any patent accompany the sales of the product.

**Step-Down High Brightness Controller with Wide Input Voltage****Marking Information**

SOT23-6L

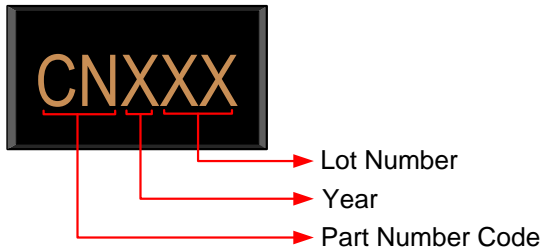
**Lot Number:** Wafer lot number's code

For Example: XX486 → 86

**Year:** Production year's last digit**Part Number Code:** Part number identification code for this product. It should be always "CN".

## Ordering Information

Part Number	Code	Ambient Operating Temperature	Junction Operating Temperature	Package	MOQ	Description
FP7130LR-G1	CN	-25°C ~ +85°C	-25°C ~ +125°C	SOT23-6L	3000 EA	Tape & Reel

## Absolute Maximum Ratings

Parameter	Symbol	Conditions	Min.	Typ.	Max.	Unit
Power Supply Voltage	$V_{IN}$	IN to GND	-0.3		90	V
RS			IN-5V		IN	V
All Other Pins			-0.3		5.5	V
Allowable Power Dissipation	$P_D$	SOT23-6L $T_A \leq +25^\circ\text{C}$			455	mW
Junction Temperature	$T_J$				+150	°C
Junction to Ambient Thermal Resistance	$\theta_{JA}$				220	°C / W
Junction to Case Thermal Resistance	$\theta_{JC}$				150	°C / W
Operating Temperature			-25		+85	°C
Storage Temperature	$T_S$	SOT23-6L	-40		+150	°C
SOT23-6L Lead Temperature		(soldering, 10 sec)			+260	°C

## IR Re-flow Soldering Curve

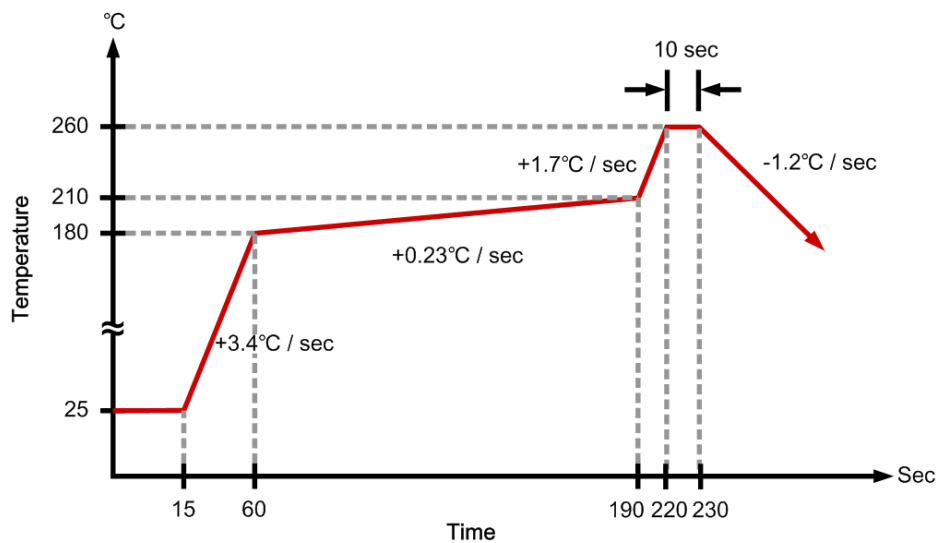

This datasheet contains new product information. Advanced Analog Technology reserves the rights to modify the product specification without notice. No liability is assumed as a result of the use of this product. No rights under any patent accompany the sales of the product.

Rev. 0.60

## Recommended Operating Conditions

Parameter	Symbol	Conditions	Min.	Typ.	Max.	Unit
Supply Voltage	IN		6		80	V
Ambient Operating Temperature			-25		+85	°C
Junction Operating Temperature			-25		+125	°C

## DC Electrical Characteristics (VDD=12V, T<sub>A</sub> = 25°C, unless otherwise noted)

Parameter	Symbol	Conditions	Min.	Typ.	Max.	Unit
<b>Power supply</b>						
Input Voltage	V <sub>IN</sub>		6		80	V
Shutdown Current	I <sub>SD</sub>	DIM=0V		60		uA
Quiescent Current	I <sub>Q</sub>	No Switch		0.5		mA
VCC Voltage	V <sub>CC</sub>	DIM=5V		4.9		V
<b>Current Sense</b>						
Current Sense Threshold	V <sub>IN</sub> -V <sub>RS</sub>	DIM=5V	194	200	206	mV
Sense Threshold Hysteresis				±15		%
RS Pin Input Current	I <sub>RS</sub>			8		uA
<b>Dimming</b>						
DIM enable high voltage	V <sub>EN_HIGH</sub>	V <sub>EN</sub> Rising		0.45		V
DIM enable hysteresis	V <sub>EN_HYH</sub>			50		mV
DIM pull-up current	I <sub>DIM_UP</sub>	V <sub>DIM</sub> =5V		125		uA
DIM pull-down current	I <sub>DIM_LOW</sub>	V <sub>DIM</sub> =0V		3		uA
Minimum DIM PWM frequency				0.1		kHz
Maximum DIM PWM frequency		Guarantee by Designer		32		kHz
<b>Driver</b>						
DR driver source resistor	R <sub>SOURCE</sub>	V <sub>CC</sub> =5V		2.7		Ω
DR driver sink resistor	R <sub>SINK</sub>			1		Ω
DR driver high voltage	V <sub>OH</sub>	I <sub>DR</sub> =10mA	4.8			V
DR driver low voltage	V <sub>OL</sub>	I <sub>DR</sub> =10mA			0.5	V
<b>Output Switch</b>						
Minimum on time	T <sub>ON_MIN</sub>	Guarantee by Designer		100		ns
Minimum off time	T <sub>OFF_MIN</sub>	Guarantee by Designer		100		ns
<b>Thermal Protection</b>						
Thermal shutdown				160		°C
Thermal shutdown hysteresis		Guarantee by Designer		20		°C

This datasheet contains new product information. Advanced Analog Technology reserves the rights to modify the product specification without notice. No liability is assumed as a result of the use of this product. No rights under any patent accompany the sales of the product.

## Function Description

### Steady State

The FP7130 is a versatile LED current controller that operates efficiently in continuous current mode to provide reliable power to high-brightness LEDs. Its hysteresis control architecture ensures accurate regulation of LED current by utilizing feedback from an external high-side current-sense resistor. With a wide input voltage range of 6V to 80V, this controller is ideal for various LED applications. Its low 200mV average feedback voltage effectively reduces power loss and enhances efficiency. Additionally, the FP7130 offers both analog and PWM dimming control via the DIM pin.

### System Soft Start

The voltage present on the DIM pin serves as the reference for the inductor current. To introduce a soft-start delay, an external capacitor is connected between the DIM pin and ground. During startup, an internal voltage source charges this capacitor from 0V to 5V, which enables the soft-start function.

### Dimming Control

The FP7130 offers both analog and PWM dimming control through the EN/DIM pin. When the voltage on DIM falls below 0.4V, the chip will turn off. For analog dimming, the LED current will range from 19% to 100% of the maximum current when the voltage on DIM varies between 0.45V and 2.4V. If the voltage on the EN pin exceeds 2.5V, the output LED current will be equal to the maximum LED current. In PWM dimming, the signal amplitude must exceed 3V, and a PWM frequency in the range of 0.1kHz to 32kHz should be chosen for optimal dimming linearity.

The conversion equation between V<sub>DIM</sub> and V<sub>CS</sub> is represented as follows:

$$V_{CS} = 0.083 \times V_{DIM}$$

## Application Curves

※  $V_{IN}=80V$ ,  $LED=9V$ , Inductor=68uH,  $T_A = 25^{\circ}C$ , unless otherwise noted

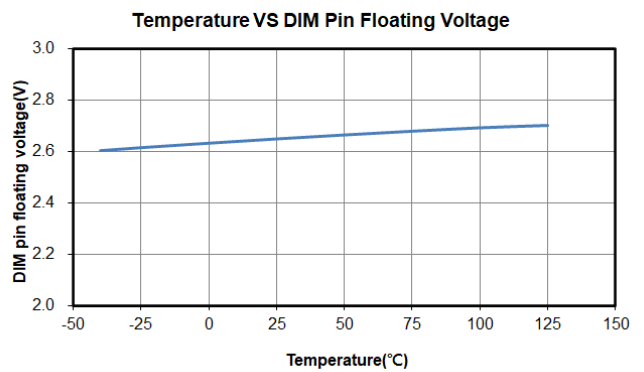
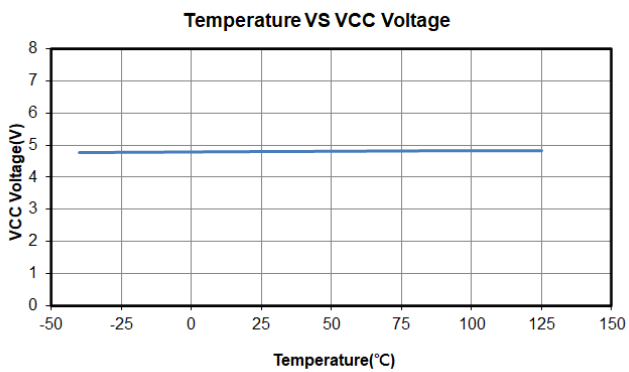
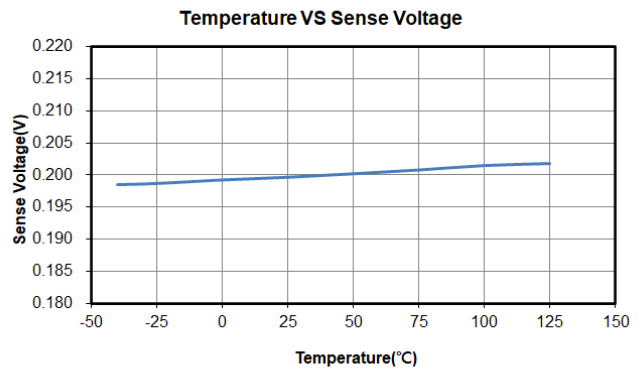
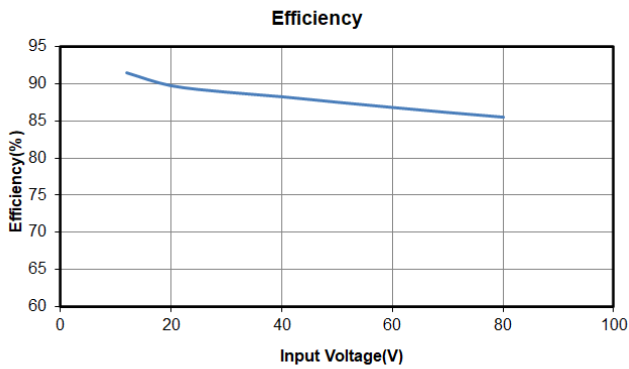
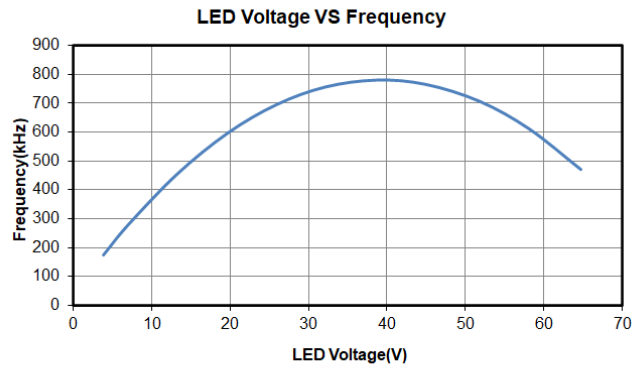
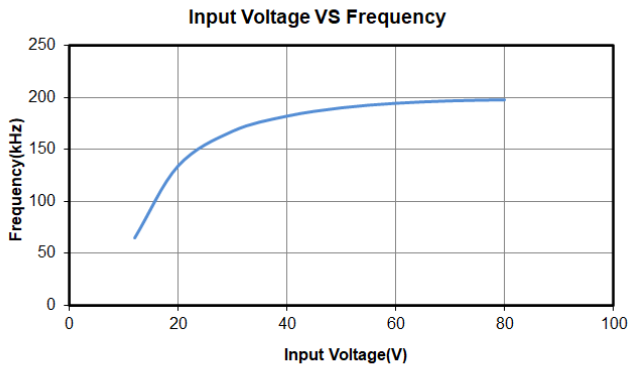
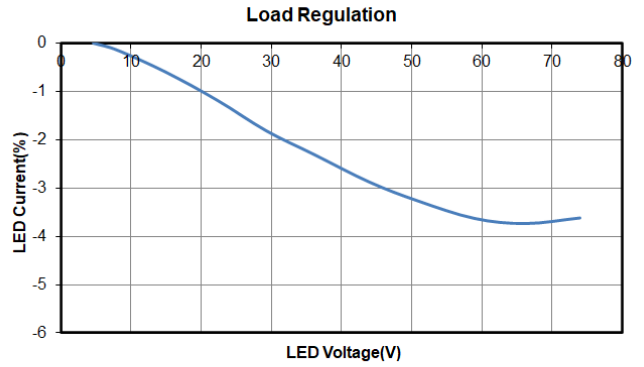
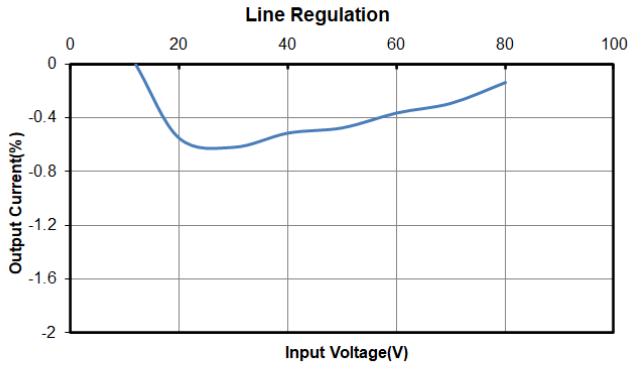

This datasheet contains new product information. Advanced Analog Technology reserves the rights to modify the product specification without notice. No liability is assumed as a result of the use of this product. No rights under any patent accompany the sales of the product.

EN ON

EN OFF

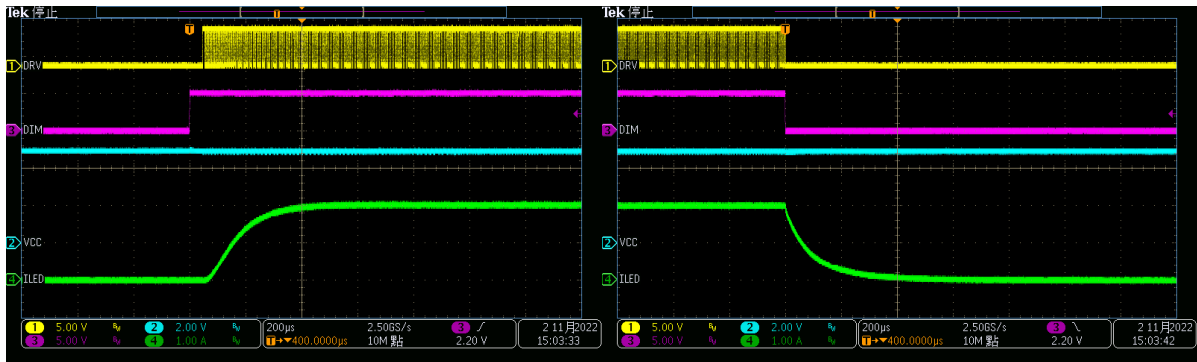

Power ON

Power OFF

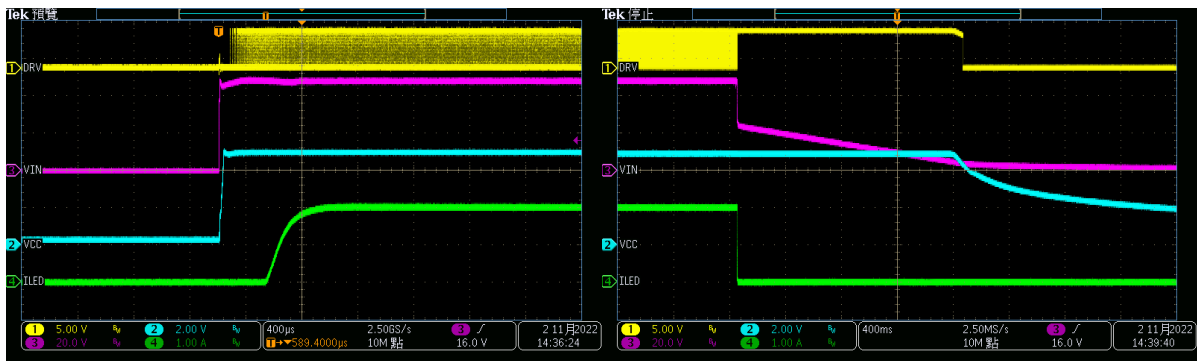

LED Open Protection

LED Open Recovery

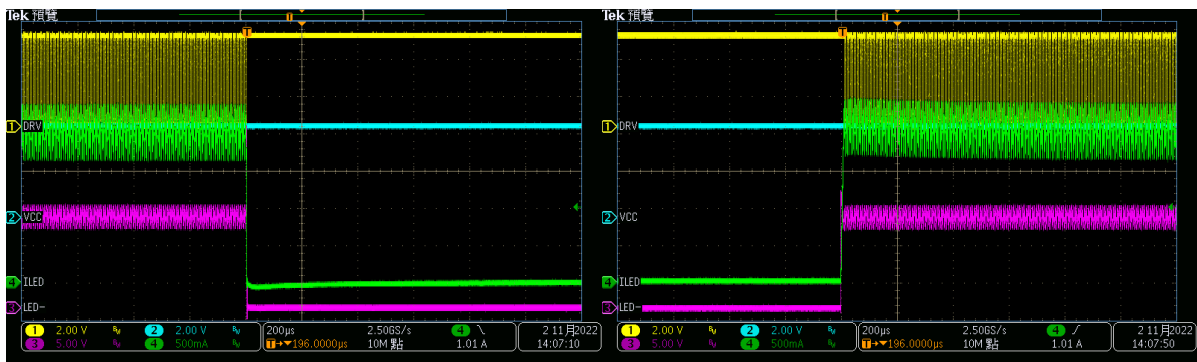

LED Short Protection

LED Short Recovery

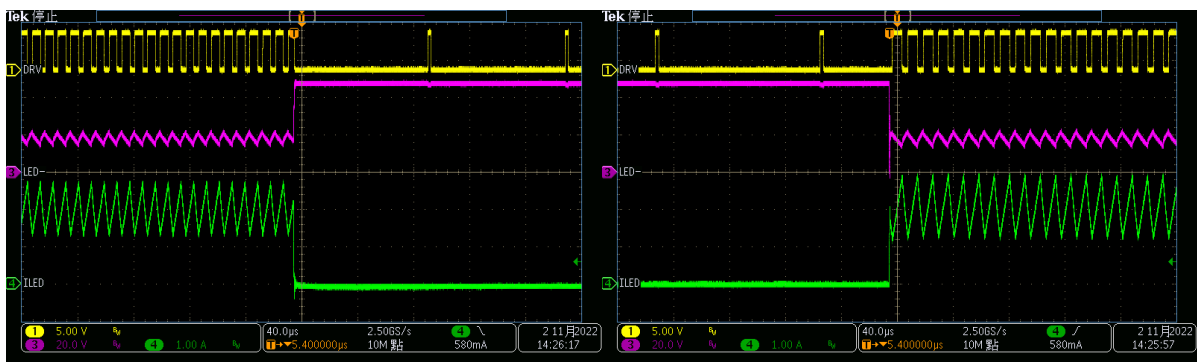

This datasheet contains new product information. Advanced Analog Technology reserves the rights to modify the product specification without notice. No liability is assumed as a result of the use of this product. No rights under any patent accompany the sales of the product.



## Suggested Layout

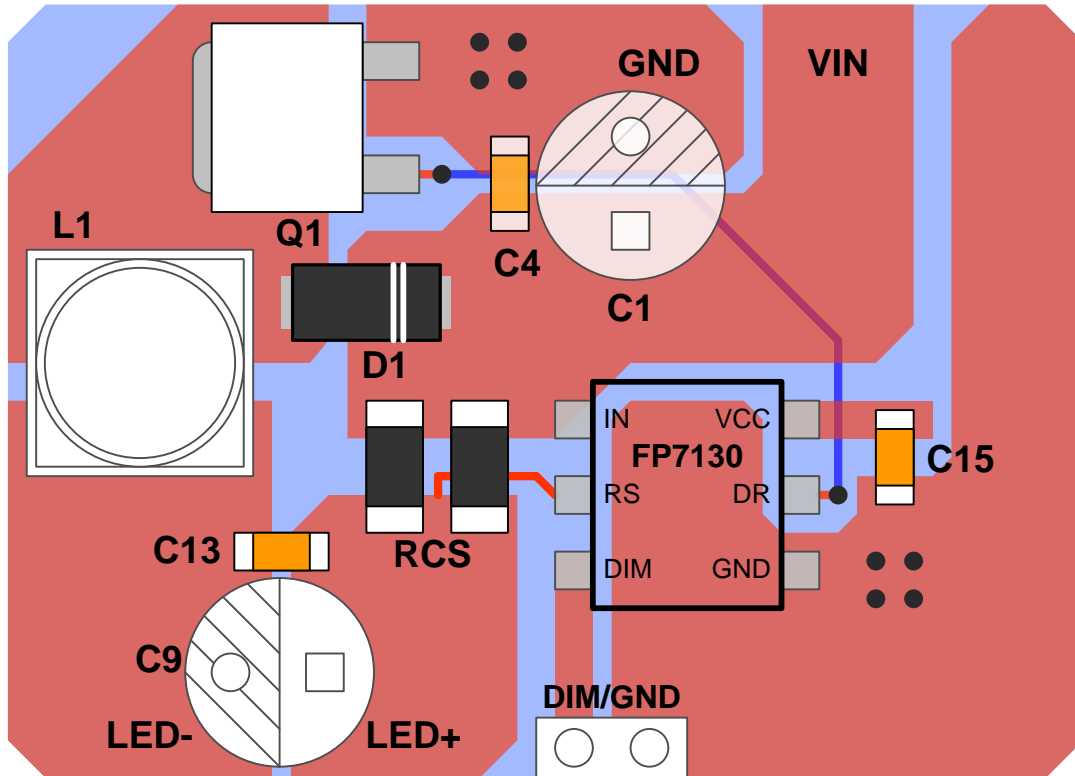

1. Keep the power traces, including the GND, SW, and VIN traces, short, direct, and wide to optimize performance.
2. Place C15 near the VCC pin as closely as possible to maintain a steady input voltage and filter noise effectively.
3. Keep the RS pin away from the switching node since it is a sensitive node.
4. Connect the GND of the C1/C4 and Q1 source pin close together directly to a ground plane. Pour copper as extensively as possible for GND.
5. Connect the VIN of the D1, RCS, C1/C4, and IC's IN pin close and directly together.

### Typical Application Circuit

- Input voltage range = 42V~80V
- Output LED voltage = 36V
- Output LED current = 2A

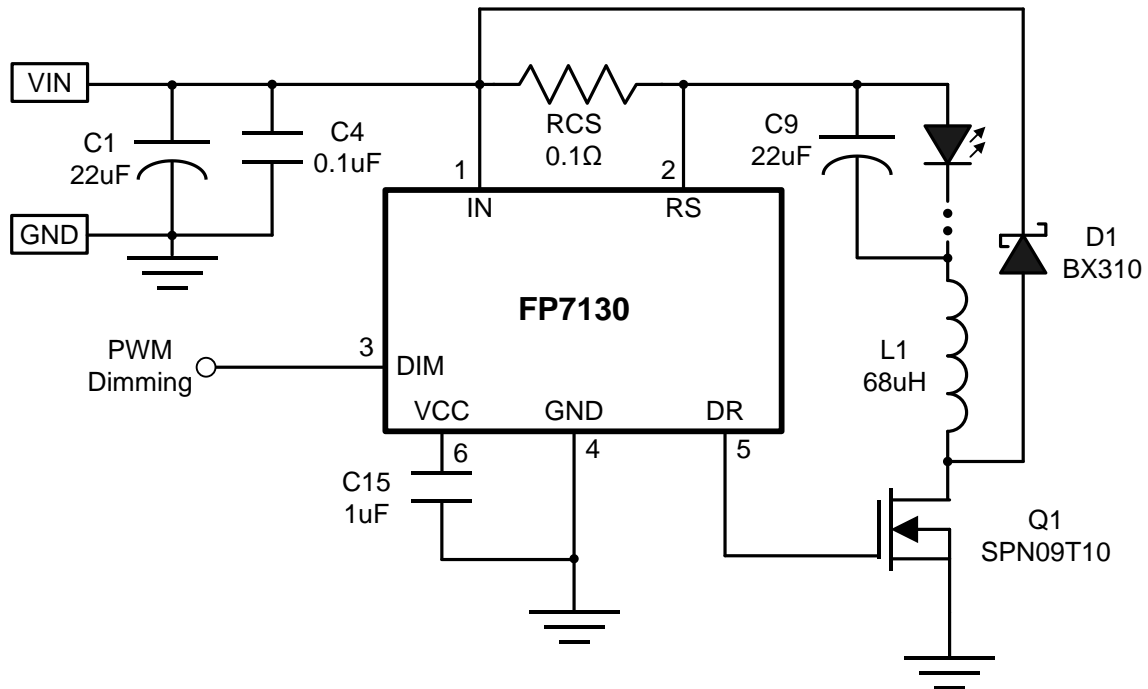

## Package Outline

SOT23-6L

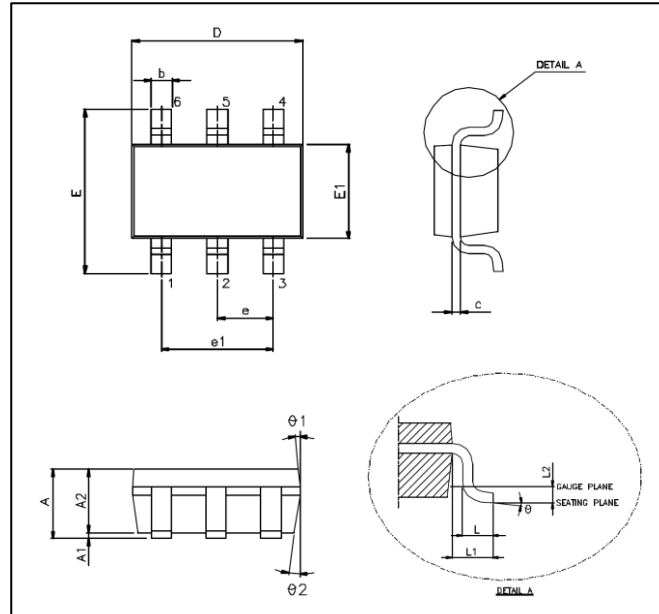

Unit: mm

Symbols	Min. (mm)	Max. (mm)
A	1.050	1.450
A1	0.050	0.150
A2	0.900	1.300
b	0.300	0.500
c	0.080	0.220
D	2.900 BSC	
E	2.800 BSC	
E1	1.600 BSC	
e	0.950 BSC	
e1	1.900 BSC	
L	0.300	0.600
L1	0.600 REF	
L2	0.250 BSC	
$\theta^\circ$	0°	8°
$\theta 1^\circ$	3°	7°
$\theta 2^\circ$	6°	15°

### Note:

1. Package dimensions are in compliance with JEDEC outline: MO-178 AB.
2. Dimension "D" does not include molding flash, protrusions or gate burrs.
3. Dimension "E1" does not include inter-lead flash or protrusions.

This datasheet contains new product information. Advanced Analog Technology reserves the rights to modify the product specification without notice. No liability is assumed as a result of the use of this product. No rights under any patent accompany the sales of the product.